

Technical Data

Specifications & Capacities

ATC 3210

Telescopic Boom All Terrain Crane
210 US ton
185 metric ton

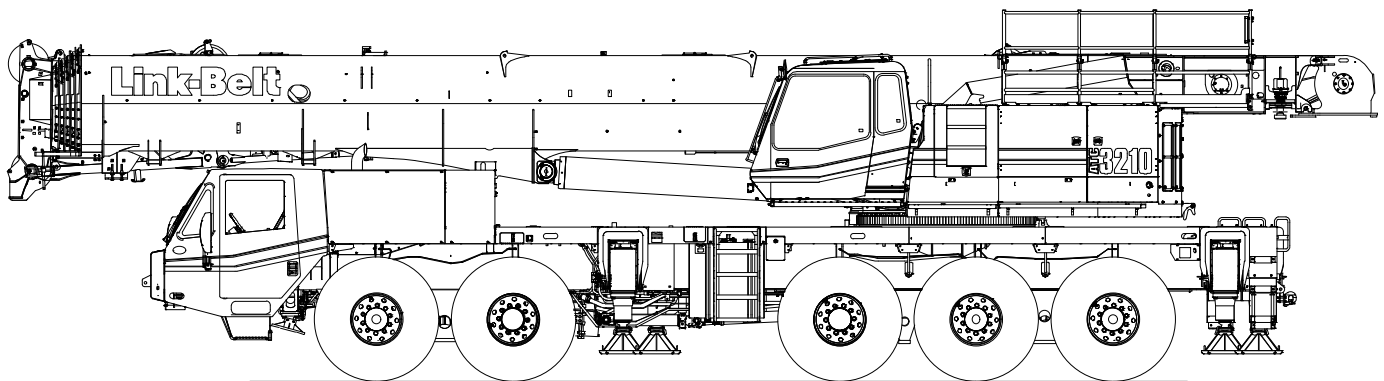

CAUTION: This material is supplied for reference use only. Operator must refer to in-cab Crane Rating Manual and Operator's Manual to determine allowable crane lifting capacities and assembly and operating procedures.

Table Of Contents

Boom, Attachments, and Upper Structure	1
Boom	1
Boom Wear Pads	1
Boom Head	1
Boom Elevation	1
Auxiliary Lifting Sheave – Optional	1
Heavy Duty Lifting Pendants Package – Optional	1
Hook Blocks and Balls – Optional	1
Fly – Optional	1
Fly Extensions – Optional	1
Upper Operator’s Cab and Controls	2
Swing	3
Central Lubrication System	3
Electrical	3
Hydraulic System	4
Pump Drive	4
Fuel Tank	4
Engine	4
Load Hoist System	5
Load Hoist Performance	5
2M Main (Front) and Optional Auxiliary (Rear) Winches	5
Counterweight	5
Carrier	7
General	7
Outriggers	7
Steering and Axles	7
Suspension	7
Ground Control Outrigger/Suspension Controls	7
Tires and Wheels	8
Brakes	8
Central Lubrication System	8
Electrical	8
Transmission	8
Fuel Tank	8
Engine	8
Hydraulic System	8
Pump Drive	8
Carrier Speeds and Gradeability	9
Lower Cab and Controls	10
Additional Equipment	11
Axle Loads – English	12
Axle Loads – Metric	13
Axle Loads with 2–Axle or 3–Axle Boom Dolly (3rd Axle Down) – English	14
Axle Loads with 2–Axle or 3–Axle Boom Dolly (3rd Axle Down) – Metric	15
General Dimensions	16
Working Range Diagram – Main Boom	17

Working Range Diagram – Main Boom + Fly	18
Boom Extend Modes	19
Main Boom Lift Capacity Charts – Standard	20
0 lb Counterweight - Fully Extended Outriggers - 360° Rotation	20
36,000 lb Counterweight - Fully Extended Outriggers - 360° Rotation	21
Main Boom Lift Capacity Charts – Optional	22
58,000 lb Counterweight - Fully Extended Outriggers - 360° Rotation	22
80,000 lb Counterweight - Fully Extended Outriggers - 360° Rotation	23
102,000 lb Counterweight - Fully Extended Outriggers - 360° Rotation	24
115,500 lb Counterweight - Fully Extended Outriggers - 360° Rotation	25
Manual & Hydraulic Offset Fly Attachment Lift Capacity Charts – Optional	26
36,000 lb Counterweight - Fully Extended Outriggers - 360° Rotation	26
Main Boom + 12 ft Offset Fly (Manual Offsets 2°, 15°, 30°, 45° & Hydraulic Offsets 2°-4°, 4.1°- 45°)	26
115,500 lb Counterweight - Fully Extended Outriggers - 360° Rotation	28
Main Boom + 12 ft Offset Fly (Manual Offsets 2°, 15°, 30°, 45° & Hydraulic Offsets 2°-4°, 4.1°- 45°)	28
Manual Offset Fly Attachment Lift Capacity Charts – Optional	30
36,000 lb Counterweight - Fully Extended Outriggers - 360° Rotation	30
200.1 ft Main Boom Length + 40 ft & 67 ft Hydraulic Offset Fly (2° - 45° Offsets)	30
115,500 lb Counterweight - Fully Extended Outriggers - 360° Rotation	31
200.1 ft Main Boom Length + 40 ft & 67 ft Manual Offset Fly (2°, 15°, 30°, 45° Offsets)	31
200.1 ft Main Boom Length + 92 ft & 117 ft Manual Offset Fly (2°, 15°, 30°, 45° Offsets)	32
Hydraulic Offset Fly Attachment Lift Capacity Charts – Optional	33
36,000 lb Counterweight - Fully Extended Outriggers - 360° Rotation	33
200.1 ft Main Boom Length + 40 ft & 67 ft Hydraulic Offset Fly (2° - 45° Offsets)	33
115,500 lb Counterweight - Fully Extended Outriggers - 360° Rotation	34
200.1 ft Main Boom Length + 40 ft & 67 ft Hydraulic Offset Fly (2° - 45° Offsets)	34
200.1 ft Main Boom Length + 92 ft & 117 ft Hydraulic Offset Fly (2° - 45° Offsets)	35
Main Boom Lift Capacity Charts – Metric	36
16.3t Counterweight - Fully Extended Outriggers - 360° Rotation	36
Main Boom Lift Capacity Charts – Optional – Metric	37
52.4t Counterweight - Fully Extended Outriggers - 360° Rotation	37
Manual & Hydraulic Offset Fly Attachment Lift Capacity Charts – Optional – Metric	38
16.3t Counterweight - Fully Extended Outriggers - 360° Rotation	38
Main Boom + 3.7m Offset Fly (Manual Offsets 2°, 15°, 30°, 45° & Hydraulic Offsets 2°-4°, 4.1°- 45°)	38
54.2t Counterweight - Fully Extended Outriggers - 360° Rotation	40
Main Boom + 3.7m Offset Fly (Manual Offsets 2°, 15°, 30°, 45° & Hydraulic Offsets 2°-4°, 4.1°- 45°)	40
Manual Offset Fly Attachment Lift Capacity Charts – Optional – Metric	42
16.3t Counterweight - Fully Extended Outriggers - 360° Rotation	42
61m Main Boom Length + 12.2m & 20.4m Manual Offset Fly (2°, 15°, 30°, 45° Offsets)	42
52.4t Counterweight - Fully Extended Outriggers - 360° Rotation	43
61m Main Boom Length + 12.2m & 20.4m Manual Offset Fly (2°, 15°, 30°, 45° Offsets)	43
61m Main Boom Length + 28m & 35.6m Manual Offset Fly (2°, 15°, 30°, 45° Offsets)	44
Hydraulic Offset Fly Attachment Lift Capacity Charts – Optional – Metric	45
16.3t Counterweight - Fully Extended Outriggers - 360° Rotation	45
61m Main Boom Length + 12.2m & 20.4m Hydraulic Offset Fly (2° - 45° Offsets)	45
52.4t Counterweight - Fully Extended Outriggers - 360° Rotation	46
61m Main Boom Length + 12.2m & 20.4m Hydraulic Offset Fly (2° - 45° Offsets)	46
61m Main Boom Length + 28m & 35.7m Hydraulic Offset Fly (2° - 45° Offsets)	47

Boom, Attachments, and Upper Structure

■ Boom

Design — Six section, formed construction of extra high tensile steel consisting of one base section and five telescoping sections. The two plate design of each section has multiple longitudinal bends for superior strength. Each telescoping section extends independently by means of one double – action, single stage hydraulic cylinder with integral holding valves.

Boom

- 44.3 – 200.1 ft (13.5 – 61m) six section boom
- Integral boom dolly connection
- Boom removal quick disconnects
- Three pinned positions of 0%, 50%, and 100% on each boom section
- Mechanical boom angle indicator
- Wind speed indicator
- Seven boom extend modes (EM1 – EM7), controlled from the operator's cab, provide superior capacities by varying the extension of the telescoping sections:
 - EM1 extends to 200.1 ft (61m)
 - EM2 extends to 185.5 ft (56.5m)
 - EM3 extends to 168.5 ft (51.4m)
 - EM4 extends to 153.4 ft (46.8m)
 - EM5 extends to 122.2 ft (37.2m)
 - EM6 extends to 124.1 ft (37.8m)
 - EM7 extends to 92.5 ft (28.2m)
- Maximum tip height for each extend mode is:
 - EM1 is 210.9 ft (64.3m)
 - EM2 is 196.3 ft (59.8m)
 - EM3 is 179.5 ft (54.7m)
 - EM4 is 164.5 ft (50.1m)
 - EM5 is 133.6 ft (40.7m)
 - EM6 is 124.1 ft (37.8m)
 - EM7 is 104.1 ft (31.7m)

Boom Wear Pads

- Wear pads with Teflon inserts that self – lubricate the boom sections, inserts are universal for the boom.
- Bottom rear wear pads are universal for all boom sections.
- Top front wear pads are universal for all boom sections
- Top rear wear pads are common for T2, T3, T4, and T5 boom sections

Boom Head

- Seven 16.53 in (41.99cm) root diameter nylon sheaves to handle up to 16 parts of line with auxiliary lifting sheave
- Easily removable wire rope guards
- Rope dead end lugs on either side of the boom head
- Boom head is designed for quick–reeve of the hook block

Boom Elevation

- One double acting hydraulic cylinder with integral holding valve
- Boom elevation: -2.1° to 82.5°

Auxiliary Lifting Sheave – Optional

- Single 16.53 in (41.99cm) root diameter nylon sheave
- Easily removable wire rope guards
- Does not affect erection of the fly or use of the main head sheaves
- Can be stored on right side of the boom without removal

Heavy Duty Lifting Pendants Package – Optional

- Two pendant assemblies with 16.42 in (41.99cm) root diameter nylon sheaves
- Necessary to achieve greater than 16 parts of line

Hook Blocks and Balls – Optional

- 35 ton (31.8t) 1 sheave quick–reeve hook block with safety latch
- 66 ton (60t) 3 sheave quick–reeve hook block with safety latch
- 100 ton (91t) 5 sheave quick–reeve hook block with safety latch
- 140 ton (127t) 7 sheave quick–reeve hook block with safety latch
- 210 ton (190.5t) 10 sheave quick–reeve twin hook block with safety latch
- 12 ton (10.9t) swivel hook ball with safety latch

Fly – Optional

- 40 – 67 ft (12.2 – 20.4m) two piece bi-fold lattice fly, stowable, offsettable to 2° , 15° , 30° , and 45° . Maximum tip height is 277.3 ft (84.5m). Minimum of 36,000 lb (16 329kg) of counterweight required.
- 12-40-67 ft (3.7-12.2-20.4m) three piece bi-fold lattice fly, stowable, offsettable to 2° , 15° , 30° , and 45° . Maximum tip height is 277.3 ft (84.5m). Minimum of 36,000 lb (16 329kg) of counterweight required.
- 12-40-67 ft (3.7-12.2-20.4m) three piece bi-fold lattice fly, stowable hydraulically offsettable to 2° through 45° . Maximum tip height is 277.3 ft (84.5m). Minimum of 36,000 lb (16 329kg) of counterweight required.

Fly Extensions – Optional

- One 25 ft (7.62m) lattice extension, equipped with one 16.38 in (41.6cm) root diameter nylon deflector sheave to be mounted between the boom head and fly options. Maximum tip height of 302.0 ft (92.1m). Minimum of 58,000 lb (26 308kg) of counterweight required.
- Two 25 ft (7.62m) lattice extensions, equipped with one 16.38 in (41.6cm) root diameter nylon deflector sheave to be mounted between the boom head and fly options. Maximum tip height of 326.7 ft (99.6m). Minimum of 58,000 lb (26 308kg) of counterweight required.

■ Upper Operator's Cab and Controls

Environmental Cab – Fully enclosed, one person cab of galvanneal steel structure with acoustical insulation.

Equipped with:

- Tilting cab up to 20°
- Tinted and tempered glass windows
- Five way adjustable, cushioned seat with headrests, and seat belt
- Extra—large fixed front window with windshield wiper and washer
- Swing up roof window with windshield wiper
- Sliding left side door with large fixed window
- Sliding right side window for ventilation
- Engine dependent warm – water heater with air ducts for front windshield defroster and cab floor
- Defroster fan for the front window
- Bubble level
- Circulating fan
- Sun screen
- LED dome light
- Cup holder
- Fire extinguisher
- Left side viewing mirror
- Two position travel swing lock
- AM/FM Radio

Air Conditioning – Integral with cab heating system utilizing the same ventilation outlets

Armrest Controls – Two dual axis electronic joystick controllers or optional single axis electronic controllers for:

- Swing
- Boom hoist
- Main front winch
- Auxiliary rear winch – optional
- Drum rotation indication
- Drum rotation indicator activation switch
- Winch high/low speed disable switch(es)
- Cab heater and A/C controls
- Throttle lock switch
- Throttle set/resume switch
- Cab tilt switch
- Counterweight handling switch
- Warning horn button
- Swing park brake

Foot Controls

- Boom Telescope
- Swing brake
- Engine throttle

Right Front Console – Controls and indicators for:

- Warning horn button
- Function disable switch
- Cab floodlights switch
- Console dimmer switch
- 2–12 volt accessory outlets (Switched & Unswitched)
- Emergency engine shutdown
- Windshield wiper/washer switch
- Outrigger keypad

- Upper ignition switch
- Lower ignition switch
- Boom floodlights switch
- Rotating beacon/strobe light switch
- Hydraulic offset fly switch – optional

Camera Display – Located on dash console

- Displays right side of upper
- Displays main and auxiliary winches

Cab Instrumentation – Ergonomically positioned LCD display, CANBUS instrumentation for crane operation including:

- Tachometer
- Change Hydraulic filter indication
- Engine water temperature
- Fuel level
- Hydraulic oil temperature
- Stop engine
- Check engine
- Wait to start
- High exhaust temperature light⁽¹⁾
- Exhaust system cleaning light⁽¹⁾
- Exhaust system cleaning Disabled light⁽¹⁾
- Swing park brake light
- Fine metering function set & %
- Diesel exhaust fluid (DEF) Low Light⁽¹⁾
- Engine air filter high restriction Light
- Engine Running Hours
- Hydraulic Oil Life Indicator
- Engine Oil Life Indicator
- General Service Indicator
- Carrier engine indicator lights and gauges
- Engine oil pressure
- Battery voltage
- Engine hours
- Fuel rate (gal/hr)
- Engine load
- Third wrap indicator activation & setup
- Engine Diagnostics
- Electronic Control Diagnostics
- Outrigger level indicator
- Exhaust system cleaning inhibit switch⁽¹⁾
- Exhaust system cleaning initiate switch⁽¹⁾
- Service interval indicator
 - Hydraulic oil
 - Engine oil
 - Miscellaneous – user defined

Diagnostic Center – Located on the left side of the front panel below the windshield

- Engine diagnostic
- RCL CANBUS diagnostic
- Boom CANBUS diagnostic
- Crane Controller USB diagnostic
- RCL controller USB diagnostic
- Manual boom control connection
- Manual crane control connection

⁽¹⁾ (Tier 4f/Stage IV engine only)

Link-Belt Pulse – The Link-Belt in-house designed, total crane operating system that utilizes the display as a readout and operator interface for the following systems:

- **Rated capacity limiter** – LCD graphic audio – visual warning system integrated into the dash with anti – two block and function limiter. Operating data includes:
 - Crane configuration
 - Boom length
 - Boom head height
 - Allowed load and % of allowed load
 - RCL light bar
 - Boom angle
 - Radius of load
 - Actual load
 - Wind speed
 - Highlighted unit of measurement on working screen
 - Active pin/latch status
 - Telescope operation displayed in real time
 - Counterweight installation/removal
 - Third wrap indicator
 - Diagnostics
 - Outrigger position sensing
 - Drum rotation direction indicator
 - Operator settable alarms (include):
 - Maximum and minimum boom angles
 - Maximum tip height
 - Maximum boom length
 - Swing left/right positions
 - Operator defined area (imaginary plane)
- **Telematics** – Cellular–based data logging and monitoring system that provides:
 - Location and operational settings
 - Routine maintenance
 - Crane and engine monitoring
 - Diagnostic and fault codes
- **Extend control module (ECM)**
 - Controls the extend modes
 - Diagnostics
- **Electronic controllers**
 - Controls all load lifting functions
 - Diagnostics
- **Fine metering**
 - Controls the reaction speeds of the main and auxiliary winches, boom hoist, and swing functions
 - Diagnostics

Integrated Third Wrap Indicator – Optional – Link-Belt Pulse color display visually and audibly warns the operator when the wire rope is on the first/bottom layer and when the wire rope is down to the last three wraps.

Integrated Third Wrap Function Kickout – Optional – Link–Belt Pulse color display visually and audibly warns the operator when the wire rope is on the first/bottom layer and provides a function kickout when the wire rope is down to the last three wraps.

Internal RCL Light Bar – Visually informs the operator when crane is approaching maximum load capacity with a series of green, yellow, and red lights.

External RCL Light Bar – Optional – Visually informs the ground crew when crane is approaching maximum load capacity with a series of green, yellow, and red lights.

■ Swing

Motor/Planetary – Two bi-directional hydraulic swing motors mounted to planetary reduction units for 360° continuous smooth swing at 1.5 rpm.

Swing Park Brake – 360°, electric over hydraulic, (spring applied/hydraulic released) multi–disc brake mounted between the speed reducer and the motor. Operated by a switch in the operator’s cab.

Swing Brake – 360°, foot operated, hydraulic applied disc brake mounted to the reduction unit.

Swing Lock – Two – position swing lock (boom over the front or rear) operated from the operator’s cab.

360° Positive Swing Lock – Optional – Meets New York City requirement.

■ Central Lubrication System

Automated lubrication unit that injects grease into the turntable bearing, boom hoist cylinder pins, boom foot pins, house lock (2–position), and cab tilt cylinder. Activated by a timer on the ignition switch.

■ Electrical

Two batteries provide 12 – volt operation and starting. CANBUS wiring and components.

Swing Alarm – Audio/Visual warning device signals when the upper is swinging.

Lights

- Two LED working lights on the front of the cab
- Work Lighting Package
 - Includes six (6) LED lights
 - Working light on top of the cab
 - Right side of superstructure facing forward
 - Left & right upper work platforms
 - Left & right sides of superstructure facing down
- One amber strobe beacon on top of the cab
- Boom floodlight – Single
- Boom floodlight – Dual
- Boom floodlight – High intensity remote controlled

Power Panel – Sealed power panel containing:

- Battery disconnects
- Hour meter
- Fuses, circuit breakers, relays, diodes, resistors
- Control modules

■ Hydraulic System

Main Pumps

- Two piston pumps for boom hoist and telescope
- Two piston pumps for main and auxiliary winches
- One piston pump for swing
- One piston pump for counterweight removal and hydraulic fly option
- One gear pump for engine fan
- One gear pump for upper oil cooler fan
- The upper engine powers the pumps. Combined pump capacity of 218 gpm (825.2Lpm).

Hydraulic Reservoir – 148 gal (560.2L) capacity equipped with sight level gauge. Diffusers built in for deaeration, and magnetic drain plug.

Filtration

- One, 7 – micron filter inside hydraulic reservoir, accessible for easy replacement
- One, 7 – micron charge filter next to the reservoir with an in – cab indicator light
- One suction strainer inside the hydraulic reservoir

Counterbalance Valves – Boom extend cylinder and boom hoist cylinder are equipped with counterbalance valves to provide load lowering and prevents accidental load drop when hydraulic power is suddenly reduced.

Hydraulic Oil Cooler – Mounted on right side above telescoping valve. Removes heat from the hydraulic oil.

Boom Hoist Float Valves – For transporting the boom over the rear of the crane with a boom dolly. Allows hydraulic oil within the boom hoist cylinder to flow between piston side and case side.

Swing Brake Release Valve – For transporting the boom over the rear of the crane with a boom dolly. Holds the 360° swing park brake in the released position allowing free rotation of the upper structure.

■ Pump Drive

All pumps are mechanically driven by the diesel engine.

■ Fuel Tank

- One 58 gal (219.5L) capacity aluminum diesel tank
- One 5 gal (18.9L) capacity diesel exhaust fluid (DEF) plastic tank

■ Engine

Specification	Cummins QSB–6.7	
	Tier 4f/Stage IV ⁽¹⁾	Tier 3/Stage IIIA ⁽²⁾
Emissions Compliance Level:		
Maximum allowable sulfur content of fuel (PPM):	15	5,000
Numbers of cylinders	6	6
Cycle	4	4
Bore and Stroke: inch (mm)	4.21 x 4.88 (106.9 x 124)	4.21 x 4.88 (106.9 x 124)
Piston Displacement: in ³ (cm ³)	408 (6 702)	408 (6 702)
Max. Brake Horsepower: hp (kW)	215 (160) @ 1,800 rpm	205 (152) @ 1,800 rpm
Peak Torque: ft lb (Nm)	700 (949) @ 1,500 rpm	685 (928) @ 1,500 rpm
Alternator: volts – amps	12 – 160	12 – 160
Crankcase Capacity: qt (L)	19 (18)	19 (18)
<ul style="list-style-type: none"> • Water/fuel separator w/ heater and water in fuel (WIF) sensor • 120–volt block heater – Tier 4f/Stage IV • 220–volt block heater – Tier 3 / Stage IIIA • Grid heater – 200 amp • Mechanically driven, variable speed, engine controlled, viscous fan clutch • ⁽¹⁾ Can only be sold and/or operated where Tier 4f/Stage IV off–highway emission standards are accepted. • ⁽²⁾ Can only be sold and/or operated where Tier 3/Stage IIIA off–highway emission standards are accepted. 		

■ Load Hoist System

Load Hoist Performance

Main (Front) and Auxiliary (Rear) Winches — 7/8 in Rope										
Layer	Maximum Line Pull		Normal Line Speed		High Line Speed		Layer		Total	
	lb	kN	ft/min	m/min	ft/min	m/min	ft	m	ft	m
1	25,955	115.5	131	39.9	262	79.9	125	38.1	125	38.1
2	23,418	104.2	145	44.2	291	88.7	138	42.0	263	80.1
3	21,332	94.9	160	48.8	319	97.2	152	46.3	414	126.1
4	19,588	87.1	174	53.0	348	106.0	165	50.3	579	176.5
5	18,108	80.5	188	57.3	376	114.6	179	54.6	758	231.0
6	16,835	74.9	202	61.5	405	123.4	192	58.5	950	289.5

Wire Rope Application	Diameter	Type	Maximum Permissible Load	
			lb	kN
Main	Standard	7/8	37x7 non-rotating — right lang lay (Type KC)	
	Optional	7/8	34x7 rotation resistant — right regular lay (Type ZB)	
	Optional	7/8	34x7 rotation resistant — right regular lay (Type YB)	
Auxiliary	Standard	7/8	37x7 non-rotating — right lang lay (Type KC)	
	Optional	7/8	34x7 rotation resistant — right regular lay (Type ZB)	
	Optional	7/8	34x7 rotation resistant — right regular lay (Type YB)	

2M Main (Front) and Optional Auxiliary (Rear) Winches

- Axial piston, full and half displacement (2-speed) motors driven through planetary reduction unit for positive control under all load conditions
- Grooved lagging
- Power up/down mode of operation
- Hoist drum cable followers — optional
- Drum rotation indicators
- Drum diameter: 15 in (38.1cm)
- Rope diameter: 22mm (0.866 in)
- Rope length:
 - Main (Front) 950 ft (289.5m)
 - Auxiliary (Rear) 700 ft (213m) or 950 ft (289.5m)
- Maximum rope storage: 951 ft (289.9m)
- Terminator style socket and wedge

Optional — 79,500 lb (36.1t) in addition to standard counterweight for a total of 115,500 lbs (52.4t) counterweight for additional capacities for:

- 58,000 lb (26.3t) counterweight
- 71,500 lb (32.4t) counterweight
- 80,000 lb (36.3t) counterweight
- 102,000 lb (46.3t) counterweight
- 115,500 lb (52.4t) counterweight

Low speed jobsite travel is offered for all counterweight configurations and a boom dolly or boom trailer may be required for on-highway travel.

■ Counterweight

Standard — Total of 36,000 lbs (16.3t) of total counterweight consisting of two hydraulically removable counterweights. Assembled and disassembled by hydraulic cylinders controlled from the operator's cab with capacities for:

- 0 lb (0t) counterweight
- 14,000 lb (6.3t) counterweight
- 36,000 lb (16.3t) counterweight

Optional — 44,000 lb (20t) in addition to standard counterweight for a total of 80,000 lb (36.3t) counterweight for additional capacities for:

- 58,000 lb (26.3t) counterweight
- 71,500 lb (32.4t) counterweight
- 80,000 lb (36.3t) counterweight

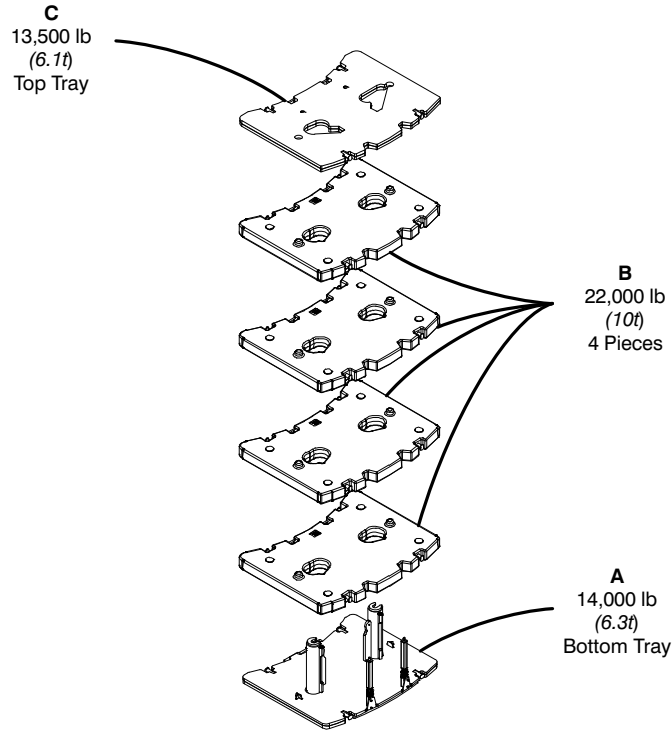

Counterweight Packages			36,000 lb (16.3t) – Standard					
			80,000 lb (36.3t) – Optional					
			115,500 lb (52.4t) – Optional					
Counterweight Modules			A 14,000 lb (6.3t)	B 22,000 lb (10t)	B 22,000 lb (10t)	B 22,000 lb (10t)	B 22,000 lb (10t)	C 13,500 lb (6.1t)
Counterweight Usage Configurations	0	0						
	A	14,000 lb (6.3t)	X					
	A,B	36,000 lb (16.3t)	X	X				
	A,B,B	58,000 lb (26.3t)	X	X	X			
	A,B,B,C	71,500 lb (32.4t)	X	X	X			X
	A,B,B,B	80,000 lb (36.3t)	X	X	X	X		
	A,B,B,B,B	102,000 lb (46.3t)	X	X	X	X	X	
	A,B,B,B,B,C	115,500 lb (52.4t)	X	X	X	X	X	X

Carrier

General

- 9 ft 10 in (3.0m) wide
- 28 ft 9 in (8.76m) wheel base (centerline of first axle to centerline of fifth axle)
- **Frame** — Box — type, torsion resistant, welded construction made of high tensile steel. Equipped with front and rear tie — down lugs and access ladders.

Outriggers

Boxes — Two double box, front and rear welded to the carrier frame

Beams and Jacks — Four dual stage beams with Confined Area Lifting Capacities (CALC) provide selectable outrigger extensions of full, intermediate, and retracted positions. Jacks with integral check valves, hydraulically controlled from the operator's cab and on both sides of the carrier. fifth front bumper outrigger with integral check valves is hydraulically controlled from the operator's cab, both sides of carrier, and at the front bumper of carrier.

Pontoons

- **Main** — Four stow'n go, 22.25" (56.52cm) square steel pontoons with a contact area of 385 in² (2 483.8cm²) can be stored for road travel under the outrigger boxes
- **Front Bumper** — One, lightweight, self-storing, 16" (40.6cm) diameter steel pontoon with a contact area of 201 in² (1 296cm²)

Outrigger Work Station Floodlights — LED Flood lights are mounted at each outrigger beam and 5th outrigger.

Jack Reaction

- **Main** — 189,800 lb (844.3kN) force and 492 psi (3 392.2kPa) ground bearing pressure. Consult factory for base rating ground bearing pressure information.
- **Front Bumper** — 68,000 lb (302.5kN) force and 338 psi (2 330kPa) ground bearing pressure

Steering and Axles

- Sheppard full integral master gear/slave gear steering system provides hydraulic assisted steering with mechanical link between steering wheel and wheels

On Highway (Primary) Steering Mode — Axles 3, 4, and 5 will automatically steer in combination with axles 1 and 2 based on travel speed:

On—Highway (Primary)			
Speed	Less than 18.6 mph (30km/h)	18.6-31 mph (30-50km/h)	Greater than 31 mph (50km/h)
Axle 1	Steered	Steered	Steered
Axle 2	Steered	Steered	Steered
Axle 3	Steered	Locked	Locked
Axle 4	Steered	Locked	Locked
Axle 5	Steered	Steered	Locked

Off Road (Auxiliary) Steering Modes — Four independent modes consisting of:

- **All Wheel:** Axles 1, 2, 3, 4, and 5
- **Diagonal (Crab):** Axles 1, 2, 3, 4, and 5
- **Independent Rear:** Axles 3, 4, and 5
- **Drive Away From Walls:** Temporary crab

The front, all wheel, and diagonal (crab) steering modes are controlled from the steering wheel and are selected by controls in the driver's cab. Switches in the driver's cab control the rear steering mode through the steering module display.

- **Emergency Steering** — A pump is flange-mounted to the transmission and provides hydraulic pressure to the steering circuit as long as the crane is in motion
- **Drive** — 10 x 6 for on/off—highway travel
- **Axle 1** — Steered, driven
- **Axle 2** — Steered
- **Axle 3** — Steered
- **Axle 4** — Steered, driven
- **Axle 5** — Steered, driven
- **Inter—Axle Differential Lock** — Traction aiding device that locks axles 1, 4, and 5. Operated by a switch in the carrier cab.
- **Transverse (Cross—Axle) Differential Locks** — Traction aiding device that locks differentials within axles 1, 4, and 5. Operated by a momentary switch in the carrier cab.

Suspension

Hydro — pneumatic, lockable with level adjustment and automatic ride height leveling. All axles have longitudinal and transverse trailing arms with leveling adjustment and lockable cylinders. The carrier can be raised, lowered, and tilted side to side by controls in the carrier cab that adjust the suspension cylinders to aid in machine setup.

- Cylinder stroke: —4.5 in (—11.43cm)/+3.5 in (8.89cm) at ride height

Ground Control Outrigger/Suspension Controls

Environmentally sealed and ergonomically positioned, control stations located on both sides of the carrier with controls for crane operations including:

- Start and stop carrier engine
- Throttle carrier engine up and down
- Raise suspension on outriggers
- Outrigger operation including:
 - Extends and retracts two beams together
 - Extends and retracts all main jacks together
 - Extend and retract fifth (bumper) outrigger
 - Automatic leveling on outriggers
- Outrigger lighting
- Bubble level

■ Tires and Wheels

Standard – Ten (single) 525/80R25 tires on aluminum disc wheels

Optional – Ten (single) 445/95R25 tires on aluminum disc wheels

- Tire inflation kit – optional
- Spare tires and wheels – optional

■ Brakes

Service – Air anti-lock (ABS) braking system. Disc brakes on all wheel ends. Dual circuit compressed air system with air dryer.

Parking/Emergency – Spring loaded type, acting on 3rd, 4th, and 5th axles automatically apply when air pressure drops below 40 psi (275kPa) in both circuits.

Intarder – Hydrodynamic driveline brake that is integral to the transmission. Activated by a switch in the carrier cab and controlled by a lever on the steering column.

Traction Control – ABS activated traction control to limit wheel slip of axles 2, 4, and 5.

■ Central Lubrication System

Automated lubrication unit that injects grease into the steering gear arms, steering knuckles, axle king pins, and suspension cylinders. Activated by a timer on the ignition switch.

■ Electrical

Battery – Three batteries provide 12 volt starting and operation, easily accessible battery disconnects, and battery jumping posts

Lights

- Front lighting includes two main daytime running/headlights, two high beam lights, two LED parking/directional indicators, and three LED cab marker lights
- Side lighting includes four parking/directional indicators per side
- LED rear lighting includes two parking/directional indicators, two parking/brake lights, two reverse lights, three marker lights, and a license plate light
- Other equipment includes hazard/warning system, cab LED light, instrument panel light, signal horn, two outrigger LED lights on each side, and 5th outrigger light
- One amber strobe beacon behind the cab

■ Transmission

Main Transmission – Automated – ZF AS-Tronic (no clutch pedal) manual transmission with 12 forward gears and 2 reverse gears.

Auxiliary Transmission – Air actuated manual transmission with high/low range.

■ Fuel Tank

- One 95 gal (359.6L) capacity aluminum fuel tank
- One 10 gal (37.8L) capacity diesel exhaust fluid (DEF) plastic tank

■ Engine

Specification	Cummins ISX 15	Cummins QSX15
Emission Compliance Level:	EPA 2017 ⁽¹⁾	Tier 3/Stage IIIA ⁽²⁾
Maximum Allowable Sulfur Content of Fuel (PPM):	15	5,000
Numbers of cylinders	6	6
Cycle	4	4
Bore and Stroke: inch (mm)	5.39 x 6.65 (136.9x169)	5.39 x 6.65 (136.9x169)
Piston Displacement: in ³ (cm ³)	912 (14 945)	912 (14 945)
Max. Brake Horsepower: hp (kW)	550 (410) @ 2,000 rpm 564 (421) @ 1,700 rpm	555 (413) @ 1,800 rpm 520 (387) @ 2,100 rpm
Peak Torque: ft lb (Nm)	1,850 (2 508) @ 1,200 rpm	1,744 (2 364) @ 1,400 rpm
Alternator: volts – amps	12 – 160	12 – 160
Crankcase Capacity: qt (L)	48 (45.4)	48 (45.4)

- Cruise control
- Cummins ISX Three stage engine compression brake
- Thermostatically controlled, hydraulically driven radiator fan
- 120 volt engine block heater – ISX
- Ether injection system – optional on ISX
- Grid heater starting aid standard on QSX
- 220 volt engine block heater – QSX
- Cummins QSX Two stage compression brake

(1) Can only be sold and/or operated where EPA 2017 on-highway emission standards are accepted.

(2) Can only be sold and/or operated where Tier 3/Stage IIIA off-highway emission standards are accepted.

■ Hydraulic System

All functions are hydraulically powered allowing positive, precise control with independent or simultaneous operation of all functions.

Main Pumps

- Two section fixed displacement gear pump for 1st and 2nd axle steering circuits, suspension, outriggers, and 3rd and 4th axle steering circuits
- One fixed displacement gear pump for 5th axle steering circuit
- One fixed displacement piston pump for cooling fan circuit
- Combined pump capacity of 66 gpm (249.8Lpm)

Hydraulic Reservoir – 57 gal (215.7L) capacity equipped with sight level gauge. Diffusers built in for deaeration.

Filtration – Two 10 micron, full flow return line filters. All oil is filtered prior to return to reservoir. Accessible for easy filter replacement.

■ Pump Drive

- Engine fan, outriggers, steering, and suspension pumps mounted to the back of engine
- Rear steering pump mounted to back of air compressor
- Ground driven pump mounted to back of transmission

Carrier Speeds and Gradeability

ZF AS–Tronic Transmission		Speed				Gradeability (@ peak torque Except Creep @ Idle)	
Gear	Ratio	High Range (0.804)		Low Range (1.781)		% Grade	
		mph	km/h	mph	km/h	Min.	Max.
12th	0.78	62.00	99.78	26.33	42.37	1.51	5.20
11th	1.00	45.50	73.23	20.54	33.06	2.46	6.95
10th	1.27	35.83	57.66	16.17	26.02	3.51	9.06
9th	1.62	28.09	45.21	12.68	20.41	4.81	11.78
8th	2.10	21.67	34.87	9.78	15.74	6.54	15.49
7th	2.69	16.91	27.21	7.64	12.30	8.63	20.04
6th	3.56	12.78	20.57	5.77	9.29	11.68	26.75
5th	4.57	9.96	16.03	4.49	7.23	15.20	34.52
4th	5.78	7.87	12.67	3.55	5.71	19.42	43.84
3rd	7.41	6.14	9.88	2.77	4.46	25.09	56.38
2nd	9.59	4.74	7.63	2.14	3.44	27.01	60.61
1st	12.29	3.70	5.95	1.67	2.69	26.87	60.29
Reverse (1)	11.38	4.00	6.44	1.80	6.13	26.90	60.36
Reverse (2)	8.88	5.12	8.24	2.31	7.85	27.03	60.66
1st @ 700 rpm	12.29	1.30	2.09	0.58	0.93		
Reverse (1) @ 700 rpm	11.38	1.40	2.25	0.63	1.01		
Reverse (2) @ 700 rpm	8.88	1.79	2.88	0.81	1.30		

Based on a gross vehicle weight of 136,000 lb (61 688.5kg) using 525/80R25 tires

■ Lower Cab and Controls

Environmental Cab — Fully enclosed, one person cab of composite structure with acoustical insulation. Equipped with:

- Tinted and tempered glass windows
- Roll down left side window for ventilation
- Intermittent windshield wiper and washer
- Six way adjustable and air suspended driver's seat with seat belt
- Two heated and electrically adjustable side view mirrors
- Engine dependent warm—water heater with air ducts for windshield defroster and cab floor
- Adjustable sun visor
- LED dome light
- Fire extinguisher

Air Conditioning — Integral with cab heating system utilizing the same ventilation outlets

Overhead Console — Located above the sun visor

- Document storage unit
- AM/FM Radio
- Strobe beacon switch

Camera Display — Located on dash console:

- Displays right side of machine
- Displays rear view

Power Panel — Sealed power panel behind carrier cab containing:

- Main circuit breakers & relays
- Rear steer modules
- ABS modules
- 12/24 volt convertor

Cab Instrumentation — Ergonomically positioned instrumentation for driving including:

- Speedometer with odometer, hour meter, trip meter, and clock
- Tachometer
- Front and rear system air pressure with warning indicator
- Diesel exhaust fluid (DEF) level with warning indicator⁽¹⁾

Dash Mounted Controls For:

- Carrier lights
- Console dimmer switch
- Remote mirror control switches
- Mirror heating switch
- Cab heater/air conditioning switch
- Fresh/Recirculation air switch
- Park brake air valve
- Trailer brake air valve
- Carrier engine ignition switch

Dash Mounted Indicators For:

- Turn signal indication
- High beam headlights

Right Side Diagonal LCD Display — Ergonomically positioned on the right of driver's dash panel, digital instrumentation and indicators for crane operations including:

Gauges

- Engine water temperature
- Engine oil pressure
- Fuel level
- Voltmeter

Indicator Lights

- Regeneration inhibit⁽¹⁾
- Check engine
- Stop engine
- Exhaust regeneration⁽¹⁾
- High exhaust temperature⁽¹⁾
- Wait to start
- Malfunction indicator lamp⁽¹⁾
- Engine air filter high restriction light
- Cruise
- Park brake
- ABS
- Trailer ABS
- Steer computer
- Steer pump
- Steer hydraulic oil level
- Transaxle (cross—axle) differential lock
- Inter—axle differential lock
- Transfer case
- Travel mode
- Ride height
- Diesel Exhaust Fluid (DEF) level⁽¹⁾
- Seat belt
- Traction control

Diagnostic Screens

- Engine
- After treatment
- Suspension/Outriggers
- Intarder

Right Side Console — Controls and indicators for:

- Transmission gear shifting
- Transmission digital readout
- Cruise controls
- Engine compression brake controls
- Steering electronic control panel
- Console dimmer switch
- Auxiliary transmission range selector switch
- Intarder on/off switch
- Diesel particulate filter switch⁽¹⁾
- Regeneration inhibit switch⁽¹⁾
- Fan override switch
- ABS Traction control switch
- Transaxle (cross—axle) differential lock switch with indicator light
- Inter—axle differential lock switch with indicator light
- Travel mode switch
- Front axles (axles 1 & 2) suspension height switch
- Rear axles (axles 3—5) suspension height switch
- Ride height switch
- 2/12 volt accessory outlet (switched & unswitched)

Steering Column Controls For:

- Turn signal switch
- High beam switch
- Steering wheel adjustments
- Warning horn
- Hazard light switch
- Intarder brake control lever
- Intermittent windshield wiper and washer

Foot Controls For:

- Carrier service brakes
- Engine throttle

⁽¹⁾ (EPA 2017 engine only)

Fuse & Diagnostic Center — Located inside cab behind seat contains:

- Fuses, Relays
- Control Modules
- Diagnostic ports
 - Suspension diagnostic
 - ABS Diagnostic
 - Cab display diagnostic
 - Intarder Diagnostic
 - Transmission Diagnostic
 - Steering Diagnostic

■ Additional Equipment

Standard:

- Aluminum full deck fenders with mud flaps
- One right side aluminum storage box with ladder
- Air hose connection ports
- Clearance flags
- Front and rear anchor shackles
- Pneumatic and electrical quick disconnect connections mounted to the rear for trailer or boom dolly brakes and lights

Optional:

- Rear mounted pintle hook
- Boom removal kit

Axle Loads – English

Base crane with full tanks of fuel and no counterweight	Gross Vehicle Weight (1)	Axle 1	Axle 2	Axle 3	Axle 4	Axle 5
	lb	lb	lb	lb	lb	lb
	124,480	24,944	24,488	24,641	25,342	25,066
Driver in carrier cab	250	177	177	-34	-34	-34
Remove pontoons	-431	-15	-15	-134	-134	-134
Ether injector	5	4	4	-1	-1	-1
Rear pintle hook	44	-13	-13	23	23	23
16.00R25 445/95R25) tires (instead of standard)	-1,008	-202	-202	-202	-202	-202
Carrier cab strobe light	5	4	4	-1	-1	-1
Hoist drum follower – auxiliary	96	-25	-25	49	49	49
Auxiliary winch with 700 ft (213m) of 7/8" (22mm) wire rope	3,102	-959	-959	1,673	1,673	1,673
Remove auxiliary winch with 700 ft (213m) of 7/8" (22mm) wire rope	-2,886	915	915	-1,572	-1,572	-1,572
Rear winch roller	96	-36	-36	56	56	56
Remove 950 ft (289.5m) of wire rope from front (main) winch	-1,454	334	334	-707	-707	-707
Remove 700 ft (213mm) of wire rope from rear (auxiliary) winch	-1,071	292	292	-552	-552	-552
Substitute 700 ft (213mm) of rope with 950 ft (289.5m) of rope - rear (auxiliary)	383	-104	-104	197	197	197
Substitute 950 ft (289.5m) of rope with 700 ft (213m) of rope - front (main)	383	-88	-88	186	186	186
360° mechanical swing lock	151	-52	-52	85	85	85
Boom launching option	125	-20	-20	55	55	55
Floodlight to the front of the boom base section	17	6	6	2	2	2
Fly mounting brackets to boom base section for fly options	237	110	110	5	5	5
12 ft (3.7m) manual and hydraulically offsettable, lattice fly - stowed	2,273	1,742	1,742	-404	-404	-404
12-40 ft (3.7-12.2m) manual and hydraulically offsettable, two-piece (bi-fold) lattice fly - stowed	3,812	2,187	2,187	-187	-187	-187
12-40-67 ft (3.7-12.2-20.4m) manual and hydraulically offsettable, three-piece (bi-fold) lattice fly - stowed	4,995	2,452	2,452	30	30	30
Additional components for hydraulically offsettable fly	389	223	223	-19	-19	-19
Auxiliary lifting sheave	112	103	103	-32	-32	-32
35 ton (31.8t) 1 sheave hook block at front bumper	1,100	855	855	-204	-204	-204
66 ton (60t) 3 sheave hook block at front bumper	1,900	1,478	1,478	-352	-352	-352
100 ton (91t) 5 sheave hook block at front bumper	2,250	1,750	1,750	-417	-417	-417
140 ton (127t) 7 sheave hook block at front bumper	2,850	2,216	2,216	-528	-528	-528
210 ton (190.5t) 10 sheave hook block at front bumper	3,745	2,913	2,913	-693	-693	-693
12 ton (10.9t) hookball at front bumper	722	562	562	-134	-134	-134

(1) Adjust gross vehicle weight and axle loading according to component weight. All weights are $\pm 3\%$.

Tire	Maximum Axle Load @ 50 mph Average Speed
20.5R25 (525/80R25) on aluminum disc wheels	28,004 lb
16.00R25 (445/95R25) on aluminum disc wheels	29,224 lb

Axle Loads – Metric

Base crane with full tanks of fuel and no counterweight	Gross Vehicle Weight ⁽¹⁾	Axle 1	Axle 2	Axle 3	Axle 4	Axle 5
	kg	kg	kg	kg	kg	kg
	56 463	11 314	11 108	11 177	11 495	11 370
Driver in carrier cab	113	80	80	-16	-16	-16
Remove pontoons	-195	-7	-7	-61	-61	-61
Ether injector	2	2	2	0	0	0
Rear pintle hook	20	-6	-6	11	11	11
16.00R25 (445/95R25) tires (instead of standard)	-457	-91	-91	-91	-91	-91
Carrier cab strobe light	2	2	2	0	0	0
Hoist drum follower - main	44	-11	-11	22	22	22
Auxiliary winch with 700 ft (213m) of 7/8" (22mm) wire rope	1 407	-435	-435	759	759	759
Remove auxiliary winch with 700 ft (213m) of 7/8" (22mm) wire rope	-1 309	415	415	-713	-713	-713
Hoist drum follower - auxiliary	44	-16	-16	25	25	25
Remove 950 ft (289.5m) of wire rope from front (main) winch	-659	151	151	-321	-321	-321
Remove 700 ft (213m) of wire rope from rear (auxiliary) winch	-486	133	133	-250	-250	-250
Substitute 700 ft (213m) of rope with 950 ft (289.5m) of rope - rear (auxiliary)	173	-47	-47	89	89	89
Substitute 950 ft (289.5m) of rope with 700 ft (213m) of rope - front (main)	173	-40	-40	84	84	84
360° mechanical swing lock	69	-23	-23	39	39	39
Boom launching option	57	-9	-9	25	25	25
Floodlight to the front of the boom base section	8	3	3	1	1	1
Fly mounting brackets to boom base section for fly options	107	50	50	2	2	2
12 ft (3.7m) manual and hydraulically offsettable, lattice fly - stowed	1 031	790	790	-183	-183	-183
12-40 ft (3.7-12.2m) manual and hydraulically offsettable, two-piece (bi-fold) lattice fly - stowed	1 729	992	992	-85	-85	-85
12-40-67 ft (3.7-12.2-20.4m) manual and hydraulically offsettable, three-piece (bi-fold) lattice fly - stowed	2 266	1 112	1 112	14	14	14
Additional components for hydraulically offsettable fly	176	101	101	-9	-9	-9
Auxiliary lifting sheave	51	47	47	-14	-14	-14
35 ton (31.8t) 1 sheave hook block at front bumper	499	388	388	-92	-92	-92
66 ton (60t) 3 sheave hook block at front bumper	862	670	670	-160	-160	-160
100 ton (91t) 5 sheave hook block at front bumper	1 021	794	794	-189	-189	-189
140 ton (127t) 7 sheave hook block at front bumper	1 293	1 005	1 005	-239	-239	-239
210 ton (190.5t) 10 sheave hook block at front bumper	1 699	1 321	1 321	-314	-314	-314
12 ton (10.9t) hookball at front bumper	327	255	255	-61	-61	-61

⁽¹⁾ Adjust gross vehicle weight and axle loading according to component weight. All weights are $\pm 3\%$.

Tire	Maximum Axle Load @ 80.5kph Average Speed
20.5R25 (525/80R25) on aluminum disc wheels	12 702.4kg
16.00R25 (445/95R25) on aluminum disc wheels	13 255.8kg

Axle Loads with 2–Axle or 3–Axle Boom Dolly (3rd Axle Down) – English

Base crane with full tanks of fuel and no counterweight	Gross Vehicle Weight ⁽¹⁾	Axle 1	Axle 2	Axle 3	Axle 4	Axle 5	Dolly
	lb	lb	lb	lb	lb	lb	lb
	124,480	19,756	19,300	20,228	20,929	20,653	23,614
Nelson 2 - axle boom dolly ⁽²⁾	6,600	0	0	0	0	0	6,600
Nelson 3 - axle boom dolly ⁽²⁾	9,000	0	0	0	0	0	9,000
Driver in carrier cab	250	177	177	-34	-34	-34	0
Remove pontoons	-431	-15	-15	-134	-134	-134	0
Ether injector	5	4	4	-1	-1	-1	0
Rear pintle hook	44	-13	-13	23	23	23	0
16.00R25 (445/95R25) tires (instead of standard)	-1,008	-202	-202	-202	-202	-202	0
Carrier cab strobe light	5	4	4	-1	-1	-1	0
Hoist drum follower - main	96	30	30	12	12	12	0
Auxiliary winch with 700 ft (213m) of 7/8" (22mm) wire rope	3,102	1,133	1,133	279	279	279	0
Remove auxiliary winch with 700 ft (213m) of 7/8" (22mm) wire rope	-2,886	-1,077	-1,077	-244	-244	-244	0
Hoist drum follower - auxiliary	96	41	41	4	4	4	0
Remove 950 ft (289.5m) of wire rope from front (main) winch	-1,454	-416	-416	-207	-207	-207	0
Remove 700 ft (213m) of wire rope from rear (auxiliary) winch	-1,071	-353	-353	-122	-122	-122	0
Substitute 700 ft (213m) of rope with 950 ft (289.5m) of rope - rear (auxiliary)	383	126	126	44	44	44	0
Substitute 950 ft (289.5m) of rope with 700 ft (213m) of rope - front (main)	383	109	109	55	55	55	1
360° mechanical swing lock	151	60	60	10	10	10	0
Boom launching option	125	6	6	38	38	38	0
Floodlight to the front of the boom base section	17	2	2	1	1	1	10
Fly mounting brackets to boom base section for fly options	237	15	15	11	11	11	173
12 ft (3.7m) manual and hydraulically offsettable, lattice fly - stowed	2,273	-39	-39	-30	-30	-30	2,441
12-40 ft (3.7-12.2m) manual and hydraulically offsettable, two-piece (bi-fold) lattice fly - stowed	3,812	130	130	98	98	98	3,258
12-40-67 ft (3.7-12.2-20.4m) manual and hydraulically offsettable, three-piece (bi-fold) lattice fly - stowed	4,995	280	280	212	212	212	3,799
Additional components for hydraulically offsettable fly	389	13	13	10	10	10	333
Auxiliary lifting sheave	112	-7	-7	-5	-5	-5	141
35 ton (31.8t) 1 sheave hook block at boom head	1,100	-55	-55	-42	-42	-42	1,335
66 ton (60t) 3 sheave hook block at boom head	1,900	-95	-95	-72	-72	-72	2,305
100 ton (91t) 5 sheave hook block at boom head	2,250	-112	-112	-85	-85	-85	2,730
140 ton (127t) 7 sheave hook block at boom head	2,850	-142	-142	-108	-108	-108	3,458
210 ton (190.5t) 10 sheave hook block at front bumper	3,745	-187	-187	-142	-142	-142	4,544
12 ton (10.9t) hookball at boom head	722	-36	-36	-27	-27	-27	876

⁽¹⁾ Adjust gross vehicle weight and axle loading according to component weight. All weights are ±3%.

⁽²⁾ Weights may vary.

Tire	Maximum Axle Load @ 50 mph Average Speed
20.5R25 (525/80R25) on aluminum disc wheels	28,004 lb
16.00R25 (445/95R25) on aluminum disc wheels	29,224 lb

Axle Loads with 2–Axle or 3–Axle Boom Dolly (3rd Axle Down) – Metric

Base crane with full tanks of fuel and no counterweight	Gross Vehicle Weight ⁽¹⁾	Axle 1	Axle 2	Axle 3	Axle 4	Axle 5	Dolly
	kg	kg	kg	kg	kg	kg	kg
	56 463	8 961	8 754	9 175	9 493	9 368	10 711
Nelson 2 - axle boom dolly ⁽²⁾	2 994	0	0	0	0	0	2 994
Nelson 2 - axle boom dolly ⁽²⁾	4 082	0	0	0	0	0	4 082
Driver in carrier cab	113	80	80	-16	-16	-16	0
Remove pontoons	-195	-7	-7	-61	-61	-61	0
Ether injector	2	2	2	0	0	0	0
Rear pintle hook	20	-6	-6	11	11	11	0
16.00R25 (445/95R25) tires (instead of standard)	-457	-91	-91	-91	-91	-91	0
Carrier cab strobe light	2	2	2	0	0	0	0
Hoist drum follower - main	44	14	14	5	5	5	0
Auxiliary winch with 700 ft (213m) of 7/8" (22mm) wire rope	1 407	514	514	126	126	126	0
Remove auxiliary winch with 700 ft (213m) of 7/8" (22mm) wire rope	-1 309	-488	-488	-111	-111	-111	0
Hoist drum follower - auxiliary	44	19	19	2	2	2	0
Remove 950 ft (289.5m) of wire rope from front (main) winch	-659	-189	-189	-94	-94	-94	0
Remove 700 ft (213m) of wire rope from rear (auxiliary) winch	-486	-160	-160	-55	-55	-55	0
Substitute 700 ft (213m) of rope with 950 ft (289.5m) of rope - rear (auxiliary)	173	57	57	20	20	20	0
Substitute 950 ft (289.5m) of rope with 700 ft (213m) of rope - front (main)	173	50	50	25	25	25	0
360° mechanical swing lock	69	27	27	5	5	5	0
Boom launching option	57	3	3	17	17	17	0
Floodlight to the front of the boom base section	8	1	1	1	1	1	5
Fly mounting brackets to boom base section for fly options	107	7	7	5	5	5	79
12 ft (3.7m) manual and hydraulically offsettable, lattice fly - stowed	1 031	-18	-18	-14	-14	-14	1 107
12-40 ft (3.7-12.2m) manual and hydraulically offsettable, two-piece (bi-fold) lattice fly - stowed	1 729	59	59	45	45	45	1 478
12-40-67 ft (3.7-12.2-20.4m) manual and hydraulically offsettable, three-piece (bi-fold) lattice fly - stowed	2 266	127	127	96	96	96	1 723
Additional components for hydraulically offsettable fly	176	6	6	5	5	5	151
Auxiliary lifting sheave	51	-3	-3	-2	-2	-2	64
35 ton (31.8t) 1 sheave hook block at boom head	499	-25	-25	-19	-19	-19	605
66 ton (60t) 3 sheave hook block at boom head	862	-43	-43	-33	-33	-33	1 046
100 ton (91t) 5 sheave hook block at boom head	1 021	-51	-51	-39	-39	-39	1 238
140 ton (127t) 7 sheave hook block at boom head	1 293	-65	-65	-49	-49	-49	1 569
12 ton (10.9t) hookball at boom head	327	-16	-16	-12	-12	-12	397

⁽¹⁾ Adjust gross vehicle weight and axle loading according to component weight. All weights are $\pm 3\%$.

⁽²⁾ Weights may vary.

Tire	Maximum Axle Load @ 80.5kph Average Speed
20.5R25 (525/80R25) on aluminum disc wheels	12 702.4kg
16.00R25 (445/95R25) on aluminum disc wheels	13 255.8kg

General Dimensions

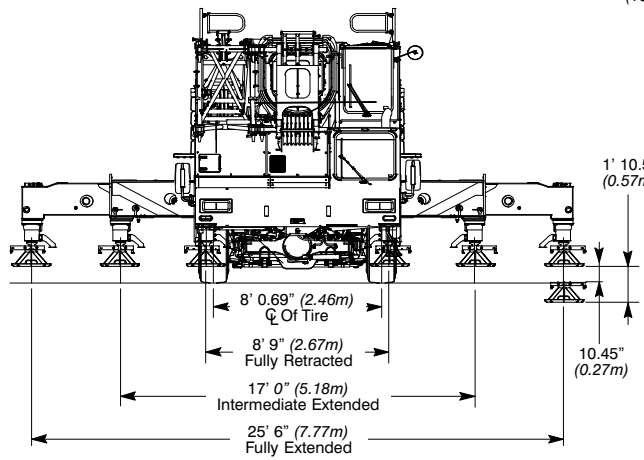
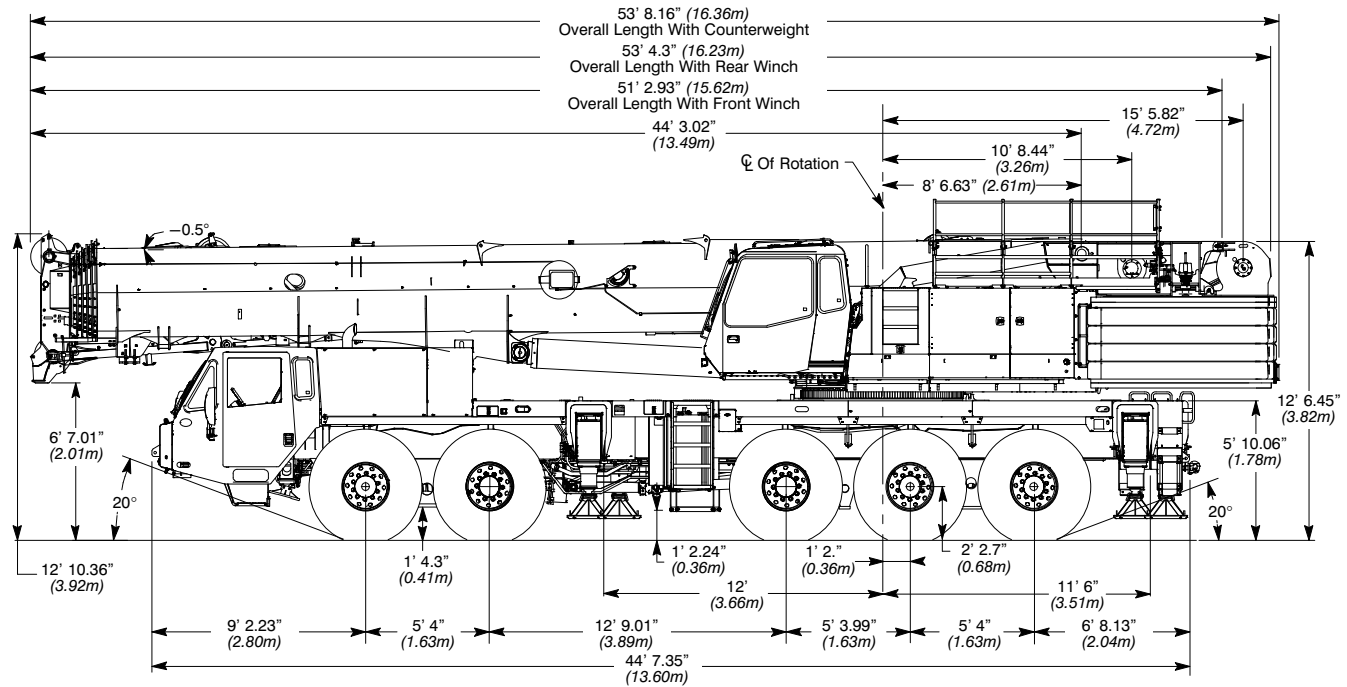

Turning Radius	20.5R25		16.00R25	
	English	Metric	English	Metric
Wall to wall over carrier	42' 0"	12.8m	41' 6"	12.6m
Wall to wall over boom	42' 6"	12.9m	42' 2"	12.8m
Wall to wall over boom attachment	44' 11"	13.7m	44' 6"	13.5m
Curb to curb	37' 1"	11.3m	36' 3"	11.04m
Centerline of tire	36' 2"	11.0m	35' 6"	10.8m

Tail Swing	English	Metric
With auxiliary winch	16' 11"	5.1m
Without auxiliary winch	14' 8"	4.7m
With Counterweight	17' 1"	5.21m

Overall Width	English	Metric
With 14,000 lb (6.3t) counterweight	9' 10"	3.0m
With 36,000–115,000 lb (16.3t–52.4t) counterweight	10' 3"	3.1m

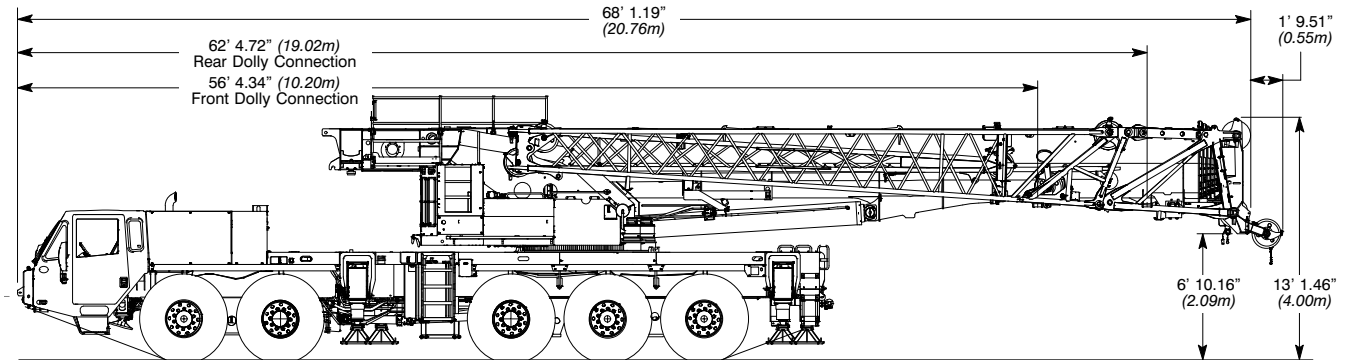

Not To Scale

Working Range Diagram – Main Boom

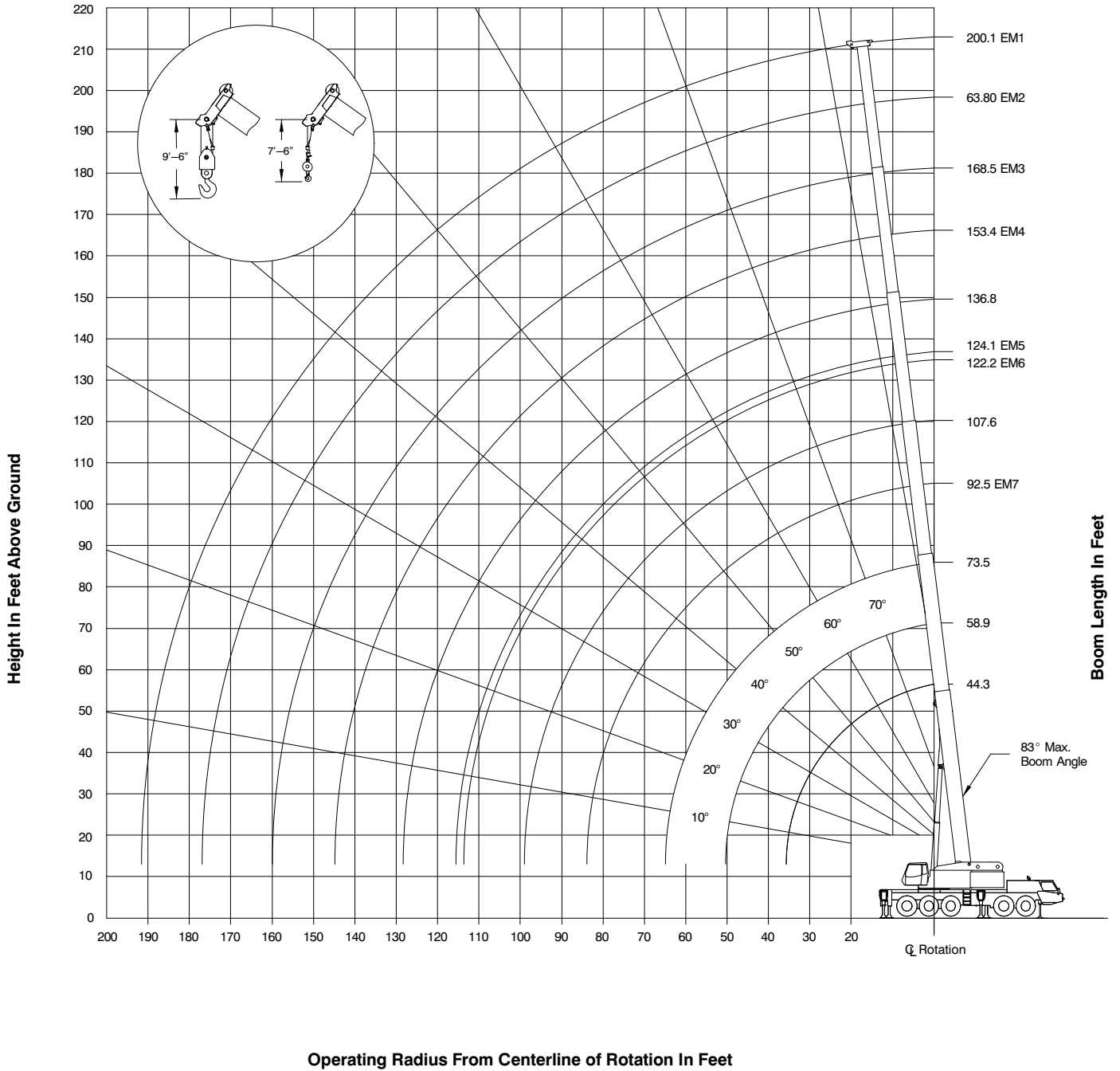

Working Range Diagram – Main Boom + Fly

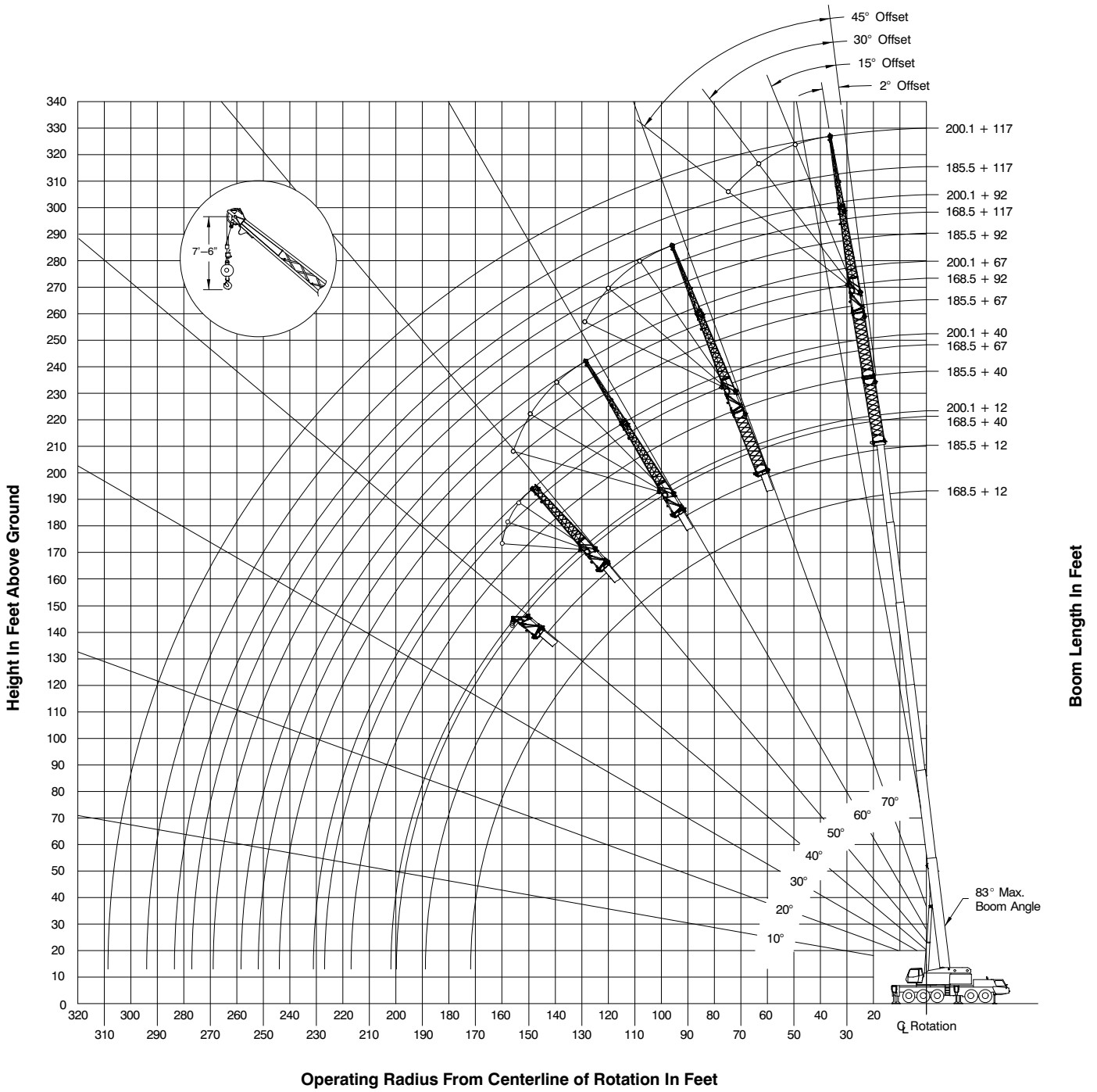

Boom Extend Modes

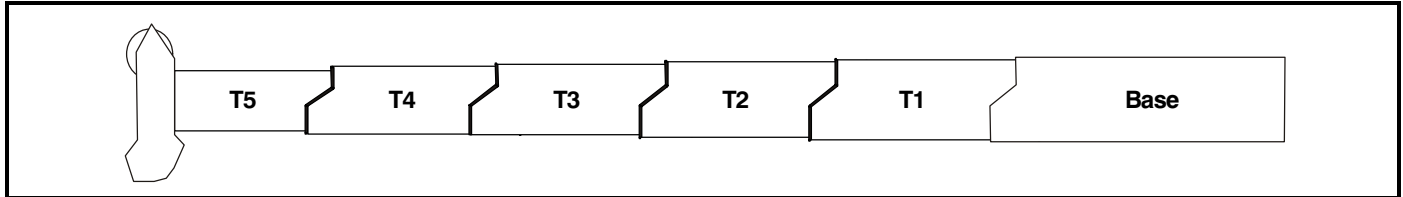

EM 1	Boom Length		Telescope Length				
	ft	m	T5	T4	T3	T2	T1
	44.3	13.5					
73.5	22.4	100%					
103.8	31.6	100%	100%				
134.9	41.1	100%	100%	100%			
167.1	50.9	100%	100%	100%	100%		
183.6	56.0	100%	100%	100%	100%	50%	
200.1	61.0	100%	100%	100%	100%	100%	

EM 2	Boom Length		Telescope Length				
	ft	m	T5	T4	T3	T2	T1
	44.3	13.5					
58.9	18.0	50%					
89.1	27.2	50%	100%				
120.3	36.7	50%	100%	100%			
152.4	46.5	50%	100%	100%	100%		
169.0	51.5	50%	100%	100%	100%	50%	
185.5	56.5	50%	100%	100%	100%	100%	

EM 3	Boom Length		Telescope Length				
	ft	m	T5	T4	T3	T2	T1
	44.3	13.5					
73.5	22.4	100%					
103.8	31.6	100%	100%				
119.3	36.4	100%	100%	50%			
135.4	41.3	100%	100%	50%	50%		
152.0	46.3	100%	100%	50%	50%	50%	
168.5	51.4	100%	100%	50%	50%	100%	

EM 4	Boom Length		Telescope Length				
	ft	m	T5	T4	T3	T2	T1
	44.3	13.5					
73.5	22.4	100%					
88.6	27.0	100%	50%				
104.2	31.8	100%	50%	50%			
120.3	36.7	100%	50%	50%	50%		
136.8	41.7	100%	50%	50%	50%	50%	
153.4	46.8	100%	50%	50%	50%	100%	

EM 5	Boom Length		Telescope Length				
	ft	m	T5	T4	T3	T2	T1
	44.3	13.5					
58.9	18.0	50%					
74.0	22.6	50%	50%				
89.6	27.3	50%	50%	50%			
105.7	32.2	50%	50%	50%	50%		
122.2	37.3	50%	50%	50%	50%	50%	

EM 6	Boom Length		Telescope Length				
	ft	m	T5	T4	T3	T2	T1
	44.3	13.5					
59.4	18.1		50%				
75.0	22.9		50%	50%			
91.0	27.7		50%	50%	50%		
107.6	32.8		50%	50%	50%	50%	
124.1	37.8		50%	50%	50%	50%	

EM 7	Boom Length		Telescope Length				
	ft	m	T5	T4	T3	T2	T1
	44.3	13.5					
59.9	18.3			50%			
75.9	23.1			50%	50%		
92.5	28.2			50%	50%	50%	

Main Boom Lift Capacity Charts – Standard

0 lb Counterweight - Fully Extended Outriggers - 360° Rotation (All Capacities Are Listed In Pounds)									
Radius (ft)	Boom Length (ft)								Radius (ft)
	44.27	58.9–59.8	73.5–75.9	88.6–92.4	103.7–107.5	119.3–124.1	134.9–136.8	151.9–153.3	
10	276,600	278,200	262,200	212,200					10
12	244,100	247,500	245,100	212,200					12
15	195,400	199,400	200,100	198,500	128,900				15
20	144,300	148,500	149,700	149,200	147,400	120,900	91,400		20
25	86,100	94,600	98,000	98,700	97,400	94,600	91,400	65,300	25
30	55,200	63,000	67,100	68,700	68,700	67,500	65,600	65,300	30
35	37,900	45,500	49,200	50,700	51,700	51,500	51,400	48,500	35
40		34,300	37,800	39,200	40,100	39,900	39,800	37,100	40
45		26,400	30,100	31,400	32,300	32,100	32,000	29,500	45
50		20,600	24,300	25,600	26,400	26,300	26,200	23,800	50
55			19,700	21,200	22,000	21,800	21,700	19,400	55
60			16,200	17,600	18,400	18,300	18,200	16,200	60
65			12,500	14,800	15,700	15,700	15,600	13,400	65
70				12,400	13,400	13,300	13,200	11,100	70
75				10,400	11,300	11,300	11,300	9,200	75
80				8,700	9,600	9,700	9,600	7,500	80
85					8,100	8,200	8,200	6,100	85
90					6,800	6,900	6,900	4,900	90
95					5,700	5,700	5,800	3,800	95
100						4,700	4,800	2,900	100
105						3,800	3,900		105
110						3,100	3,100		110
115							2,300		115

Note: Capacities depict multiple boom modes.

This information is not for crane operation. Operator must refer to the in-cab information for crane operation. Rated lifting capacities shown on fully extended outriggers do not exceed 85% of the tipping loads.

36,000 lb Counterweight - Fully Extended Outriggers - 360° Rotation (All Capacities Are Listed In Pounds)												
Radius (ft)	Boom Length (ft)											Radius (ft)
	44.3	58.9–59.8	73.5–75.9	88.6–92.4	103.7–107.5	119.3–124.1	134.9–136.8	151.9–153.3	167–168.9	183.6–185.5	200.1	
10	284,500	285,800	262,200	212,200								10
12	255,100	257,000	255,100	212,200								12
15	220,100	222,600	221,100	205,500	128,900							15
20	163,600	167,700	168,800	168,100	166,100	129,700	91,400					20
25	128,100	132,400	133,600	133,200	131,700	120,900	91,400	73,000	41,200			25
30	100,800	108,400	110,800	110,000	110,500	108,200	85,500	73,000	55,000	41,300		30
35	73,200	80,800	83,300	83,700	82,800	80,700	79,100	73,000	55,000	41,300	33,000	35
40		63,100	65,600	66,000	65,200	66,900	65,000	63,400	55,000	41,300	33,000	40
45		50,700	54,100	54,100	55,500	54,500	52,800	53,500	52,100	41,300	33,000	45
50		41,700	45,300	46,600	46,600	45,700	46,400	44,700	43,400	41,300	33,000	50
55			38,300	39,700	39,700	40,300	39,400	37,800	37,600	37,400	33,000	55
60			32,800	34,300	35,000	34,800	34,700	32,700	33,500	32,300	31,300	60
65			27,500	29,800	30,700	30,600	30,500	28,300	29,100	27,900	26,900	65
70				26,100	27,000	26,900	26,800	24,700	25,500	24,300	23,400	70
75				23,000	23,900	23,900	23,700	21,600	22,500	21,300	20,300	75
80				20,400	21,200	21,200	21,100	19,100	19,900	18,700	17,800	80
85					18,900	19,000	18,900	17,000	17,600	16,800	15,900	85
90					17,000	17,100	17,100	15,100	15,900	14,800	13,900	90
95					15,300	15,300	15,400	13,400	14,200	13,100	12,200	95
100						13,800	13,800	11,900	12,700	11,600	10,800	100
105							12,400	12,400	10,600	11,300	10,300	105
110							11,200	11,200	9,300	10,100	9,100	110
115							3,600	10,000	8,200	9,100	8,000	115
120								9,000	7,200	8,000	7,000	120
125								8,100	6,300	7,100	6,100	125
130									5,500	6,300	5,300	130
135									4,700	5,500	4,600	135
140									4,000	4,800	3,800	140
145										4,100	3,200	145
150										3,600	2,600	150
155										3,000		155

Note: Capacities depict multiple boom modes.

This information is not for crane operation. Operator must refer to the in-cab information for crane operation. Rated lifting capacities shown on fully extended outriggers do not exceed 85% of the tipping loads.

Main Boom Lift Capacity Charts – Optional

58,000 lb Counterweight - Fully Extended Outriggers - 360° Rotation (All Capacities Are Listed In Pounds)												
Radius (ft)	Boom Length (ft)											Radius (ft)
	44.27	58.9–59.8	73.5–75.9	88.6–92.4	103.7–107.5	119.3–124.1	134.9–136.8	151.9–153.3	167–168.9	183.6–185.5	200.1	
10	288,300	289,400	262,200	212,200								10
12	259,500	261,200	256,800	212,200								12
15	224,000	226,300	224,900	205,500	128,900							15
20	175,400	179,400	178,100	176,400	172,300	129,700	91,400					20
25	137,700	141,900	143,100	142,600	140,900	120,900	91,400	73,000	41,200			25
30	111,900	117,200	117,600	117,300	115,800	117,400	85,500	73,000	55,000	41,300		30
35	93,100	98,500	99,800	99,200	100,600	99,100	79,100	73,000	55,000	41,300	33,000	35
40		80,700	83,200	83,600	82,700	80,800	73,500	69,700	55,000	41,300	33,000	40
45		65,600	68,300	68,700	67,900	66,100	67,600	63,800	55,000	41,300	33,000	45
50		54,600	57,300	57,700	56,900	58,400	56,700	55,300	53,500	41,300	33,000	50
55			48,800	49,400	51,100	50,200	48,500	48,900	47,900	41,300	33,000	55
60			42,100	43,100	44,400	43,500	42,700	42,600	41,400	40,200	33,000	60
65			36,700	38,900	39,000	38,200	38,800	37,300	36,000	35,000	33,000	65
70				34,500	34,700	34,100	34,500	33,100	31,900	32,700	31,800	70
75				30,700	30,900	31,600	30,800	29,400	28,500	29,000	28,100	75
80				26,900	27,700	28,400	27,600	26,200	26,700	25,900	24,900	80
85					25,400	25,600	25,300	23,500	24,300	23,200	22,200	85
90					23,200	23,200	23,200	21,100	21,900	20,800	19,900	90
95					21,100	21,100	21,100	19,100	19,800	18,700	17,800	95
100						19,200	19,200	17,200	18,000	17,100	16,300	100
105						17,500	17,500	15,800	16,600	15,500	14,600	105
110						16,100	16,100	14,300	15,100	14,100	13,200	110
115						8,300	14,800	12,900	13,800	12,700	11,900	115
120							13,500	11,700	12,500	11,500	10,700	120
125							12,400	10,600	11,400	10,400	9,600	125
130								9,600	10,400	9,400	8,600	130
135								8,600	9,400	8,500	7,700	135
140								7,800	8,600	7,600	6,800	140
145									7,800	6,800	6,000	145
150									7,100	6,100	5,300	150
155									6,400	5,400	4,600	155
160									4,000	4,800	4,000	160
165										4,200	3,400	165
170										3,700	2,800	170
175											2,300	175

Note: Capacities depict multiple boom modes.

This information is not for crane operation. Operator must refer to the in-cab information for crane operation. Rated lifting capacities shown on fully extended outriggers do not exceed 85% of the tipping loads.

80,000 lb Counterweight - Fully Extended Outriggers - 360° Rotation (All Capacities Are Listed In Pounds)												
Radius (ft)	Boom Length (ft)											Radius (ft)
	44.3	58.9–59.8	73.5–75.9	88.6–92.4	103.7–107.5	119.3–124.1	134.9–136.8	151.9–153.3	167–168.9	183.6–185.5	200.1	
10	291,800	292,600	262,200	212,200								10
12	263,100	264,700	256,800	212,200								12
15	227,800	230,100	228,400	205,500	128,900							15
20	184,200	187,100	186,000	184,500	172,300	129,700	91,400					20
25	147,200	151,400	152,600	149,000	150,400	120,900	91,400	73,000	41,200			25
30	120,000	124,200	125,500	125,100	123,600	118,300	85,500	73,000	55,000	41,300		30
35	100,100	105,400	105,800	105,500	104,200	105,800	79,100	73,000	55,000	41,300	33,000	35
40		90,400	90,800	90,700	91,600	91,000	73,500	69,700	55,000	41,300	33,000	40
45		78,600	80,800	81,400	80,900	79,500	68,600	63,800	55,000	41,300	33,000	45
50		66,400	70,100	70,500	69,700	68,100	64,100	58,600	53,500	41,300	33,000	50
55			60,100	60,700	59,900	58,300	59,700	54,100	50,500	41,300	33,000	55
60			52,300	52,900	52,100	53,300	51,900	50,100	47,600	40,200	33,000	60
65			45,300	46,600	46,000	47,400	45,800	44,500	44,300	37,800	33,000	65
70				41,300	43,000	42,200	40,600	40,800	40,100	35,600	33,000	70
75				36,900	38,500	37,800	36,200	36,900	35,700	33,700	32,600	75
80				33,200	34,700	34,200	33,700	33,400	32,200	31,200	30,800	80
85					31,600	30,900	31,600	30,200	29,000	28,000	28,900	85
90					28,700	28,100	28,800	27,400	26,300	25,800	26,100	90
95					25,500	25,700	26,300	24,900	23,800	24,400	23,700	95
100						24,500	24,100	22,800	21,700	22,400	21,500	100
105							22,700	22,100	20,800	19,900	19,600	105
110							21,000	20,300	19,100	18,900	18,800	110
115							13,000	18,700	17,500	17,900	17,200	115
120								17,600	16,200	17,000	16,000	120
125								16,700	14,900	15,700	14,700	125
130									13,700	14,500	13,500	130
135									12,600	13,400	12,400	135
140									11,600	12,400	11,400	140
145										11,400	10,500	145
150										10,600	9,600	150
155										9,800	8,800	155
160										7,200	8,100	160
165											7,400	165
170											6,700	170
175											4,500	175
180												180
185												185

Note: Capacities depict multiple boom modes.

This information is not for crane operation. Operator must refer to the in-cab information for crane operation. Rated lifting capacities shown on fully extended outriggers do not exceed 85% of the tipping loads.

**102,000 lb Counterweight - Fully Extended Outriggers - 360° Rotation
(All Capacities Are Listed In Pounds)**

Radius (ft)	Boom Length (ft)											Radius (ft)
	44.3	58.9–59.8	73.5–75.9	88.6–92.4	103.7–107.5	119.3–124.1	134.9–136.8	151.9–153.3	167–168.9	183.6–185.5	200.1	
10	295,200	295,700	262,200	212,200								10
12	266,300	267,700	256,800	212,200								12
15	231,400	233,500	231,800	205,500	128,900							15
20	187,400	190,300	189,100	184,600	172,300	129,700	91,400					20
25	156,100	159,200	158,300	157,100	153,000	120,900	91,400	73,000	41,200			25
30	128,000	132,300	133,500	131,200	131,600	118,300	85,500	73,000	55,000	41,300		30
35	107,000	111,400	112,700	112,500	111,100	107,800	79,100	73,000	55,000	41,300	33,000	35
40		96,500	97,000	96,800	95,500	97,100	73,500	69,700	55,000	41,300	33,000	40
45		84,100	84,600	84,400	83,900	84,900	68,600	63,800	55,000	41,300	33,000	45
50		73,100	76,200	76,400	76,300	74,900	64,100	58,600	53,500	41,300	33,000	50
55			68,000	68,600	68,100	66,800	60,400	54,100	50,500	41,300	33,000	55
60			61,100	61,700	61,200	59,900	57,000	50,100	47,600	40,200	33,000	60
65			53,200	55,700	55,100	53,500	54,000	46,500	44,300	37,800	33,000	65
70				49,700	49,200	47,700	49,000	43,300	41,400	35,600	33,000	70
75				44,600	44,100	45,200	44,000	40,500	38,700	33,700	32,600	75
80				39,500	39,800	41,200	39,700	37,900	36,400	31,900	30,800	80
85					36,800	37,500	36,000	34,900	34,200	30,200	29,100	85
90					34,900	34,300	33,000	33,300	32,200	28,600	27,600	90
95					30,000	31,400	30,100	30,800	29,700	27,200	26,200	95
100						28,900	27,600	28,300	27,200	25,800	25,000	100
105							26,700	26,300	26,000	25,000	24,000	105
110							24,700	25,200	24,000	23,000	22,000	110
115							17,700	23,400	22,200	21,200	20,200	115
120								21,800	20,500	19,500	18,900	120
125								20,300	19,000	18,000	17,900	125
130									17,700	16,800	17,200	130
135									16,500	15,500	16,400	135
140									15,400	14,400	15,200	140
145										13,300	14,100	145
150										12,700	13,100	150
155										12,100	12,200	155
160										10,200	11,300	160
165											10,500	165
170											9,800	170
175											7,500	175
180												180
185												185

Note: Capacities depict multiple boom modes.

This information is not for crane operation. Operator must refer to the in-cab information for crane operation. Rated lifting capacities shown on fully extended outriggers do not exceed 85% of the tipping loads.

115,500 lb Counterweight - Fully Extended Outriggers - 360° Rotation (All Capacities Are Listed In Pounds)												
Radius (ft)	Boom Length (ft)											Radius (ft)
	44.3	58.9–59.8	73.5–75.9	88.6–92.4	103.7–107.5	119.3–124.1	134.9–136.8	151.9–153.3	167–168.9	183.6–185.5	200.1	
8	420,000 **											8
10	300,000	297,300	262,200	212,200								10
12	268,200	269,500	256,800	212,200								12
15	233,200	235,200	232,200	205,500	128,900							15
20	189,400	192,100	191,000	184,600	172,300	129,700	91,400					20
25	157,800	160,900	160,000	158,700	153,000	120,900	91,400	73,000	41,200			25
30	133,000	137,200	136,300	135,000	136,500	118,300	85,500	73,000	55,000	41,300		30
35	111,300	115,700	117,000	116,700	115,300	107,800	79,100	73,000	55,000	41,300	33,000	35
40		99,400	100,700	100,500	99,200	98,900	73,500	69,700	55,000	41,300	33,000	40
45		87,400	87,800	87,700	86,500	88,000	68,600	63,800	55,000	41,300	33,000	45
50		76,100	77,500	77,400	77,400	77,900	64,100	58,600	53,500	41,300	33,000	50
55			70,700	70,800	70,800	69,400	60,400	54,100	50,500	41,300	33,000	55
60			63,700	64,200	63,800	62,400	57,000	50,100	47,600	40,200	33,000	60
65			55,900	58,200	57,700	56,300	54,000	46,500	44,300	37,800	33,000	65
70				53,000	52,500	51,300	51,300	43,300	41,400	35,600	33,000	70
75				48,500	48,000	46,800	48,100	40,500	38,700	33,700	32,600	75
80				42,200	44,100	42,900	44,100	37,900	36,400	31,900	30,800	80
85					40,100	40,900	40,100	35,600	34,200	30,200	29,100	85
90					36,600	38,000	36,600	33,400	32,200	28,600	27,600	90
95					33,600	34,900	33,700	31,700	30,300	27,200	26,200	95
100						32,300	31,000	30,400	28,600	25,800	25,000	100
105						29,900	28,500	29,100	27,100	24,400	23,800	105
110						25,000	26,400	27,100	25,600	23,000	22,400	110
115						20,600	24,400	25,100	24,100	21,600	21,400	115
120							23,300	23,300	22,300	20,400	20,400	120
125							21,000	21,700	20,700	19,400	19,600	125
130								20,200	19,200	18,300	18,700	130
135								18,800	17,800	17,100	17,700	135
140								17,600	16,700	15,900	16,700	140
145									15,500	15,000	15,600	145
150									14,500	14,400	14,500	150
155									13,500	13,800	13,500	155
160									10,200	13,200	12,500	160
165										12,500	11,700	165
170										11,700	10,800	170
175										9,300	10,100	175
180											9,400	180
185											8,700	185

Note: Capacities depict multiple boom modes.
 ** Over rear intermediate outriggers, additional equipment required.

This information is not for crane operation. Operator must refer to the in-cab information for crane operation. Rated lifting capacities shown on fully extended outriggers do not exceed 85% of the tipping loads.

Manual & Hydraulic Offset Fly Attachment Lift Capacity Charts – Optional

36,000 lb Counterweight - Fully Extended Outriggers - 360° Rotation
(All Capacities Are Listed In Pounds)

Main Boom + 12 ft Offset Fly (Manual Offsets 2°, 15°, 30°, 45° & Hydraulic Offsets 2°-4°, 4.1°- 45°)

Radius (ft)	Boom Length (ft)												Radius (ft)
	44.2		58.9–59.8		73.5–75.9		88.6–92.4		103.7–107.5		119.3–124.1		
	2°–4°	4.1°–45°	2°–4°	4.1°–45°	2°–4°	4.1°–45°	2°–4°	4.1°–45°	2°–4°	4.1°–45°	2°–4°	4.1°–45°	
10	69,600	69,600	69,500	69,500	69,500	69,400	69,400	69,400					10
12	69,600	69,600	69,500	69,500	69,500	69,400	69,400	69,400					12
15	69,600	69,600	69,500	69,500	69,500	69,400	69,400	69,400	69,300	69,300	69,200	69,200	15
20	69,600	69,600	69,500	69,500	69,500	69,400	69,400	69,400	69,300	69,300	69,200	69,200	20
25	69,600	69,600	69,500	69,500	69,500	69,400	69,400	69,400	69,300	69,300	69,200	69,200	25
30	69,600	69,600	69,500	69,500	69,500	69,400	69,400	69,300	69,300	69,300	69,200	69,200	30
35	69,600	65,000	69,500	69,500	69,500	69,400	69,400	69,300	69,300	69,300	69,200	69,200	35
40	61,500	60,500	64,900	64,900	66,100	66,100	65,900	65,900	64,700	64,700	64,100	62,600	40
45	49,700	49,700	52,600	52,600	53,800	53,800	53,600	53,600	54,300	52,500	53,700	53,700	45
50			43,800	43,800	44,900	44,900	45,000	44,700	46,000	46,000	44,900	44,900	50
55			37,000	37,000	38,800	38,800	39,400	39,400	39,000	39,000	38,900	38,000	55
60			31,800	31,800	33,500	33,500	34,100	34,100	33,700	33,700	34,100	34,100	60
65					29,100	29,100	29,600	29,600	30,000	30,000	29,700	29,700	65
70					25,500	25,500	26,000	26,000	26,400	26,400	26,100	26,100	70
75					22,600	22,600	23,000	23,000	23,300	23,300	23,000	23,000	75
80							20,400	20,400	20,700	20,700	20,400	20,400	80
85							18,200	18,200	18,500	18,500	18,200	18,200	85
90							16,400	16,400	16,700	16,700	16,400	16,400	90
95									15,000	15,000	14,600	14,600	95
100									13,500	13,500	13,100	13,100	100
105									12,200	12,200	11,800	11,800	105
110											10,600	10,600	110
115											9,500	9,500	115
120											8,600	8,600	120
125													125
130													130
135													135
140													140
145													145
150													150
155													155

Note: Capacities depict multiple boom modes.

This information is not for crane operation. Operator must refer to the in-cab information for crane operation. Rated lifting capacities shown on fully extended outriggers do not exceed 85% of the tipping loads.

36,000 lb Counterweight - Fully Extended Outriggers - 360° Rotation (All Capacities Are Listed In Pounds)											
Main Boom + 12 ft Offset Fly (Manual Offsets 2°, 15°, 30°, 45° & Hydraulic Offsets 2°-4°, 4.1°- 45°)											
Radius (ft)	Boom Length (ft)										Radius (ft)
	134.9–136.8		151.9–153.3		167.0–168.9		183.6–185.5		200.1		
	2°–4°	4.1°–45°	2°–4°	4.1°–45°	2°–4°	4.1°–45°	2°–4°	4.1°–45°	2°–4°	4.1°–45°	
10											10
12											12
15											15
20	43,300	42,600									20
25	69,100	69,100	60,200	59,000	43,800	43,000					25
30	69,100	69,100	60,200	59,000	43,800	43,000	36,000	35,400			30
35	69,100	68,900	60,200	59,000	43,800	43,000	36,000	35,400	28,600	28,100	35
40	64,000	63,800	60,200	59,000	43,800	43,000	36,000	35,400	28,600	28,100	40
45	51,700	51,700	51,900	50,400	43,800	43,000	36,000	35,400	28,600	28,100	45
50	45,300	43,900	43,600	43,600	42,200	42,200	36,000	35,400	28,600	28,100	50
55	38,400	38,400	36,700	36,700	35,600	35,300	34,100	34,100	28,600	28,100	55
60	33,200	33,200	31,600	31,600	32,300	32,300	31,000	31,000	28,600	28,100	60
65	29,400	29,400	27,200	27,200	27,900	27,900	26,700	26,700	25,600	25,600	65
70	25,800	25,800	23,600	23,600	24,300	24,300	23,100	23,100	22,000	22,000	70
75	22,700	22,700	20,600	20,600	21,200	21,200	20,000	20,000	19,000	19,000	75
80	20,100	20,100	18,000	18,000	18,700	18,700	17,500	17,500	16,800	16,800	80
85	17,900	17,900	16,000	16,000	16,700	16,700	15,500	15,500	14,600	14,600	85
90	16,100	16,100	14,100	14,100	14,700	14,700	13,600	13,600	12,700	12,700	90
95	14,400	14,400	12,400	12,400	13,000	13,000	11,900	11,900	11,000	11,000	95
100	12,900	12,900	10,900	10,900	11,500	11,500	10,400	10,400	9,500	9,500	100
105	11,500	11,500	9,600	9,600	10,200	10,200	9,100	9,100	8,200	8,200	105
110	10,300	10,300	8,400	8,400	9,000	9,000	7,900	7,900	7,000	7,000	110
115	9,300	9,300	7,300	7,300	7,900	7,900	6,800	6,800	5,900	5,900	115
120	8,300	8,300	6,300	6,300	6,900	6,900	5,900	5,900	4,900	4,900	120
125	7,400	7,400	5,400	5,400	6,000	6,000	5,000	5,000	4,100	4,100	125
130	6,600	6,600	4,600	4,600	5,200	5,200	4,200	4,200	3,300	3,300	130
135	5,900	5,900	3,900	3,900	4,500	4,500	3,400	3,400	2,500	2,500	135
140			3,200	3,200	3,800	3,800	2,700	2,700			140
145			2,600	2,600	3,200	3,200	2,100	2,100			145
150					2,600	2,600					150
155					2,100	2,100					155

Note: Capacities depict multiple boom modes.

This information is not for crane operation. Operator must refer to the in-cab information for crane operation. Rated lifting capacities shown on fully extended outriggers do not exceed 85% of the tipping loads.

115,500 lb Counterweight - Fully Extended Outriggers - 360° Rotation (All Capacities Are Listed In Pounds)													
Main Boom + 12 ft Offset Fly (Manual Offsets 2°, 15°, 30°, 45° & Hydraulic Offsets 2°-4°, 4.1°- 45°)													
Radius (ft)	Boom Length (ft)												Radius (ft)
	44.2		58.9–59.8		73.5–75.9		88.6–92.4		103.7–107.5		119.3–124.1		
	2°–4°	4.1°–45°	2°–4°	4.1°–45°	2°–4°	4.1°–45°	2°–4°	4.1°–45°	2°–4°	4.1°–45°	2°–4°	4.1°–45°	
10	69,600	69,600	69,500	69,500	69,500	69,400	69,400	69,400					10
12	69,600	69,600	69,500	69,500	69,500	69,400	69,400	69,400					12
15	69,600	69,600	69,500	69,500	69,500	69,400	69,400	69,400	69,300	69,300	69,200	69,200	15
20	69,600	69,600	69,500	69,500	69,500	69,400	69,400	69,400	69,300	69,300	69,200	69,200	20
25	69,600	69,600	69,500	69,500	69,500	69,400	69,400	69,400	69,300	69,300	69,200	69,200	25
30	69,600	69,600	69,500	69,500	69,500	69,400	69,400	69,300	69,300	69,300	69,200	69,200	30
35	69,600	65,000	69,500	69,500	69,500	69,400	69,400	69,300	69,300	69,300	69,200	69,200	35
40	69,600	60,500	69,500	69,500	69,500	69,400	69,400	69,300	69,300	69,300	69,200	69,200	40
45	62,600	57,200	69,500	66,100	69,500	69,400	69,400	69,300	69,300	69,300	69,200	69,200	45
50			69,500	62,400	69,400	69,400	69,400	69,300	69,300	69,300	69,200	69,200	50
55			68,700	59,300	69,400	67,900	69,200	69,200	67,800	67,600	68,900	68,900	55
60			62,300	57,100	63,000	63,000	62,200	62,200	63,200	62,400	61,800	61,800	60
65					57,000	57,000	57,000	56,200	57,400	57,400	55,800	55,800	65
70					51,900	51,900	53,200	52,700	52,200	52,200	50,800	50,800	70
75					48,700	48,200	48,800	48,800	47,900	47,900	46,300	46,300	75
80							44,800	44,800	43,800	43,800	42,200	42,200	80
85							40,900	40,900	39,800	39,800	38,200	38,200	85
90							37,500	37,500	36,400	36,400	34,800	34,800	90
95									33,500	33,500	32,200	31,900	95
100									30,800	30,800	30,800	30,200	100
105									28,500	28,500	29,300	28,900	105
110											27,200	27,200	110
115											25,300	25,300	115
120											23,600	23,600	120
125											17,200	17,200	125
130													130
135													135
140													140
145													145
150													150
155													155
160													160
165													165
170													170
175													175
180													180
185													185
190													190
195													195

Note: Capacities depict multiple boom modes.

This information is not for crane operation. Operator must refer to the in-cab information for crane operation. Rated lifting capacities shown on fully extended outriggers do not exceed 85% of the tipping loads.

115,500 lb Counterweight - Fully Extended Outriggers - 360° Rotation (All Capacities Are Listed In Pounds)											
Main Boom + 12 ft Offset Fly (Manual Offsets 2°, 15°, 30°, 45° & Hydraulic Offsets 2°-4°, 4.1°- 45°)											
Radius (ft)	Boom Length (ft)										Radius (ft)
	134.9–136.8		151.9–153.3		167.0–168.9		183.6–185.5		200.1		
	2°–4°	4.1°–45°	2°–4°	4.1°–45°	2°–4°	4.1°–45°	2°–4°	4.1°–45°	2°–4°	4.1°–45°	
10											10
12											12
15											15
20	43,300	42,600									20
25	69,100	69,100	60,200	59,000	43,800	43,000					25
30	69,100	69,100	60,200	59,000	43,800	43,000	36,000	35,400			30
35	69,100	68,900	60,200	59,000	43,800	43,000	36,000	35,400	28,600	28,100	35
40	67,800	63,800	60,200	59,000	43,800	43,000	36,000	35,400	28,600	28,100	40
45	62,800	59,300	60,200	59,000	43,800	43,000	36,000	35,400	28,600	28,100	45
50	58,400	55,400	56,700	56,500	43,800	43,000	36,000	35,400	28,600	28,100	50
55	54,600	52,000	52,100	52,000	43,800	43,000	36,000	35,400	28,600	28,100	55
60	51,200	48,900	48,200	48,100	43,800	42,100	36,000	35,400	28,600	28,100	60
65	48,200	46,100	44,800	44,800	41,300	39,800	35,700	35,200	28,600	28,100	65
70	45,500	43,700	41,700	41,700	39,100	37,800	33,500	33,100	28,600	28,100	70
75	43,000	41,400	38,800	38,800	37,000	35,900	31,500	31,100	28,600	28,100	75
80	40,800	39,400	36,200	36,200	34,700	34,200	29,600	29,400	28,600	28,100	80
85	38,800	37,600	33,900	33,900	32,500	32,500	28,000	27,700	27,000	26,800	85
90	35,700	35,700	31,800	31,800	30,500	30,500	26,400	26,200	25,500	25,300	90
95	32,900	32,900	29,800	29,800	28,700	28,700	25,000	24,800	24,100	23,900	95
100	30,200	30,200	28,000	28,000	27,000	27,000	23,700	23,500	22,800	22,700	100
105	27,800	27,800	26,400	26,400	25,400	25,400	22,200	22,000	21,500	21,400	105
110	25,600	25,600	24,800	24,400	24,000	24,000	21,100	21,000	20,400	20,400	110
115	23,700	23,700	23,700	23,300	22,700	22,700	20,000	20,000	19,400	19,400	115
120	22,000	22,000	22,400	22,300	21,200	21,200	19,000	19,000	18,500	18,400	120
125	20,400	20,400	20,800	20,800	19,600	19,600	17,900	17,900	17,600	17,500	125
130	19,000	19,000	19,300	19,300	18,200	18,200	16,900	16,900	16,700	16,700	130
135	17,800	17,700	18,000	18,000	17,000	17,000	16,000	16,000	16,000	15,900	135
140			16,900	16,900	15,800	15,800	14,800	14,800	15,200	15,200	140
145			15,800	15,800	14,700	14,700	13,700	13,700	14,400	14,400	145
150			14,700	13,200	13,600	13,600	12,600	12,600	13,300	13,300	150
155					12,600	12,600	11,900	11,900	12,300	12,300	155
160					11,700	11,700	11,300	11,300	11,400	11,400	160
165					10,900	10,900	10,800	10,800	10,600	10,600	165
170					10,100	10,100	10,300	10,300	9,800	9,800	170
175							9,800	9,800	9,000	9,000	175
180							9,200	9,200	8,300	8,300	180
185									7,700	7,700	185
190									7,100	7,100	190
195									6,500	6,500	195

Note: Capacities depict multiple boom modes.

This information is not for crane operation. Operator must refer to the in-cab information for crane operation. Rated lifting capacities shown on fully extended outriggers do not exceed 85% of the tipping loads.

Manual Offset Fly Attachment Lift Capacity Charts – Optional

36,000 lb Counterweight - Fully Extended Outriggers - 360° Rotation
(All Capacities Are Listed In Pounds)

200.1 ft Main Boom Length

Radius (ft)	40 ft Manual Offset Fly				67 ft Manual Offset Fly				Radius (ft)
	2°	15°	30°	45°	2°	15°	30°	45°	
35									35
40	16,100								40
45	16,100	16,100			10,800				45
50	16,100	16,100			10,800				50
55	16,100	16,100			10,800				55
60	16,100	16,100	15,900		10,800				60
65	16,100	16,100	15,900	15,600	10,800	10,800			65
70	16,100	16,100	15,900	15,600	10,800	10,800			70
75	16,100	16,100	15,900	15,600	10,800	10,800			75
80	16,100	16,100	15,900	15,600	10,800	10,800	10,700		80
85	15,700	16,100	15,900	15,600	10,800	10,800	10,700		85
90	13,700	14,900	15,900	15,600	10,800	10,800	10,700		90
95	12,000	13,100	14,200	15,000	10,800	10,800	10,700	10,300	95
100	10,500	11,500	12,500	13,300	10,800	10,800	10,700	10,100	100
105	9,100	10,100	11,000	11,700	9,900	10,800	10,700	9,900	105
110	7,900	8,800	9,600	10,300	8,700	10,200	10,700	9,800	110
115	6,800	7,600	8,400	9,000	7,600	9,000	10,500	9,600	115
120	5,800	6,600	7,300	7,900	6,600	7,900	9,300	9,500	120
125	4,900	5,600	6,300	6,800	5,700	6,900	8,200	9,300	125
130	4,100	4,800	5,400	5,900	4,800	6,000	7,200	8,200	130
135	3,300	4,000	4,600	5,000	4,000	5,200	6,300	7,200	135
140	2,600	3,200	3,800	4,200	3,300	4,400	5,500	6,300	140
145		2,600	3,100	3,400	2,700	3,700	4,700	5,500	145
150			2,400	2,700	2,100	3,000	4,000	4,700	150
155				2,100		2,400	3,300	3,900	155
160							2,700	3,300	160
165							2,100	2,600	165

This information is not for crane operation. Operator must refer to the in-cab information for crane operation. Rated lifting capacities shown on fully extended outriggers do not exceed 85% of the tipping loads.

115,500 lb Counterweight - Fully Extended Outriggers - 360° Rotation (All Capacities Are Listed In Pounds)									
200.1 ft Main Boom Length									
Radius (ft)	40 ft Manual Offset Fly				67 ft Manual Offset Fly				Radius (ft)
	2°	15°	30°	45°	2°	15°	30°	45°	
35									35
40	16,100								40
45	16,100				10,800				45
50	16,100	16,100			10,800				50
55	16,100	16,100			10,800				55
60	16,100	16,100	15,900		10,800				60
65	16,100	16,100	15,900	15,600	10,800	10,800			65
70	16,100	16,100	15,900	15,600	10,800	10,800			70
75	16,100	16,100	15,900	15,600	10,800	10,800			75
80	16,100	16,100	15,900	15,600	10,800	10,800	10,700		80
85	16,100	16,100	15,900	15,600	10,800	10,800	10,700		85
90	16,100	16,100	15,900	15,600	10,800	10,800	10,700		90
95	16,100	16,100	15,900	15,600	10,800	10,800	10,700	10,300	95
100	16,100	16,100	15,900	15,600	10,800	10,800	10,700	10,100	100
105	16,100	16,100	15,900	15,600	10,800	10,800	10,700	9,900	105
110	16,100	16,100	15,900	15,600	10,800	10,800	10,700	9,800	110
115	16,100	16,100	15,900	15,600	10,800	10,800	10,700	9,600	115
120	16,100	16,100	15,900	15,600	10,800	10,800	10,700	9,500	120
125	16,000	16,000	15,900	15,600	10,800	10,800	10,500	9,400	125
130	15,300	15,300	15,200	15,200	10,800	10,800	10,300	9,200	130
135	14,500	14,500	14,500	14,500	10,800	10,800	10,100	9,100	135
140	13,800	13,800	13,900	13,900	10,800	10,800	9,900	9,000	140
145	13,200	13,200	13,200	13,200	10,800	10,800	9,700	8,900	145
150	12,600	12,600	12,600	12,600	10,800	10,800	9,600	8,800	150
155	12,000	12,000	12,100	12,100	10,800	10,800	9,400	8,700	155
160	11,400	11,500	11,500	11,500	10,600	10,500	9,300	8,600	160
165	10,900	11,000	11,000	11,000	10,100	10,300	9,100	8,500	165
170	10,400	10,500	10,500	10,500	9,700	9,800	9,000	8,400	170
175	9,700	10,000	10,000	10,100	9,200	9,300	8,900	8,400	175
180	9,000	9,300	9,600	9,600	8,800	8,900	8,700	8,300	180
185	8,300	8,600	8,900	9,000	8,400	8,500	8,600	8,300	185
190	7,700	8,000	8,200	8,300	8,000	8,100	8,200	8,200	190
195	7,100	7,400	7,600	7,600	7,600	7,700	7,800	7,900	195
200	6,500	6,800	6,900		7,100	7,400	7,500	7,500	200
205	6,000	6,200	6,400		6,600	7,000	7,100	7,200	205
210	5,500	5,700	5,800		6,100	6,500	6,800	6,800	210
215	5,000	5,200	5,300		5,600	6,000	6,300	6,400	215
220	4,600	4,700			5,100	5,500	5,800	5,800	220
225	4,200	4,300			4,700	5,000	5,300		225
230					4,300	4,600	4,800		230
235					3,900	4,100	4,300		235
240					3,500	3,700	3,800		240
245					3,100	3,300	3,400		245
250					2,800	2,900			250

This information is not for crane operation. Operator must refer to the in-cab information for crane operation. Rated lifting capacities shown on fully extended outriggers do not exceed 85% of the tipping loads.

115,500 lb Counterweight - Fully Extended Outriggers - 360° Rotation
(All Capacities Are Listed In Pounds)

200.1 ft Main Boom Length

Radius (ft)	92 ft Manual Offset Fly				117 ft Manual Offset Fly				Radius (ft)
	2°	15°	30°	45°	2°	15°	30°	45°	
55	8,200								55
60	8,200				6,700				60
65	8,200				6,700				65
70	8,200				6,700				70
75	8,200	8,100			6,700				75
80	8,200	8,100			6,700	6,600			80
85	8,200	8,100			6,700	6,600			85
90	8,200	8,100	8,000		6,700	6,600			90
95	8,200	8,100	8,000		6,700	6,600	6,400		95
100	8,200	8,100	8,000	7,800	6,700	6,600	6,400		100
105	8,200	8,100	8,000	7,800	6,700	6,600	6,400		105
110	8,200	8,100	8,000	7,800	6,700	6,600	6,400	6,300	110
115	8,200	8,100	8,000	7,800	6,700	6,600	6,400	6,300	115
120	8,200	8,100	8,000	7,800	6,700	6,600	6,400	6,300	120
125	8,200	8,100	8,000	7,800	6,700	6,600	6,400	6,300	125
130	8,200	8,100	8,000	7,800	6,700	6,600	6,400	6,300	130
135	8,200	8,100	8,000	7,800	6,700	6,600	6,400	6,300	135
140	8,200	8,100	8,000	7,800	6,700	6,600	6,400	6,300	140
145	8,200	8,100	8,000	7,800	6,700	6,600	6,400	6,100	145
150	8,200	8,100	8,000	7,700	6,700	6,600	6,300	5,900	150
155	8,200	8,100	8,000	7,500	6,700	6,600	6,100	5,800	155
160	8,200	8,100	7,900	7,400	6,700	6,400	5,900	5,600	160
165	8,200	8,100	7,700	7,200	6,700	6,200	5,700	5,400	165
170	8,200	8,100	7,500	7,100	6,500	6,000	5,500	5,300	170
175	8,000	8,100	7,400	7,000	6,300	5,800	5,400	5,100	175
180	7,600	7,800	7,200	6,900	6,100	5,600	5,200	4,900	180
185	7,200	7,400	7,100	6,700	5,800	5,400	5,000	4,800	185
190	6,800	7,000	6,900	6,600	5,600	5,200	4,800	4,600	190
195	6,500	6,700	6,800	6,500	5,400	5,000	4,700	4,500	195
200	6,100	6,300	6,500	6,400	5,100	4,800	4,500	4,400	200
205	5,800	6,000	6,100	6,200	4,700	4,600	4,400	4,200	205
210	5,500	5,600	5,800	5,900	4,400	4,500	4,200	4,100	210
215	5,200	5,300	5,500	5,600	4,100	4,300	4,100	4,000	215
220	4,900	5,000	5,200	5,300	3,800	4,100	3,900	3,900	220
225	4,500	4,800	4,900	5,000	3,600	3,800	3,800	3,800	225
230	4,100	4,500	4,600	4,700	3,300	3,500	3,700	3,600	230
235	3,700	4,100	4,300	4,400	3,100	3,300	3,500	3,500	235
240	3,300	3,700	4,000	4,000	2,800	3,000	3,200	3,300	240
245	2,900	3,300	3,500	3,500	2,600	2,800	2,900	3,000	245
250	2,600	2,900	3,100		2,400	2,600	2,700	2,800	250
255	2,300	2,500	2,700			2,300	2,500	2,500	255
260		2,200	2,300				2,200	2,300	260

This information is not for crane operation. Operator must refer to the in-cab information for crane operation. Rated lifting capacities shown on fully extended outriggers do not exceed 85% of the tipping loads.

Hydraulic Offset Fly Attachment Lift Capacity Charts – Optional

36,000 lb Counterweight - Fully Extended Outriggers - 360° Rotation
(All Capacities Are Listed In Pounds)

200.1 ft Main Boom Length

Radius (ft)	40 ft Hydraulic Offset Fly				67 ft Hydraulic Offset Fly				Radius (ft)
	30° - 45°	2° - 15°	15° - 30°	30° - 45°	2° - 15°	15° - 30°	30° - 45°	30° - 45°	
40	16,100								40
45	16,100				10,800				45
50	16,100	16,100			10,800				50
55	16,100	16,100			10,800				55
60	16,100	16,100	15,900		10,800				60
65	16,100	16,100	15,900	15,600	10,800	10,800			65
70	16,100	16,100	15,900	15,600	10,800	10,800			70
75	16,100	16,100	15,900	15,600	10,800	10,800			75
80	16,100	16,100	15,900	15,600	10,800	10,800	10,700		80
85	15,700	16,100	15,900	15,600	10,800	10,800	10,700		85
90	13,700	14,900	15,900	15,600	10,800	10,800	10,700		90
95	12,000	13,100	14,200	15,000	10,800	10,800	10,700	10,300	95
100	10,500	11,500	12,500	13,300	10,800	10,800	10,700	10,100	100
105	9,100	10,100	11,000	11,700	9,900	10,800	10,700	9,900	105
110	7,900	8,800	9,600	10,300	8,700	10,200	10,700	9,800	110
115	6,800	7,600	8,400	9,000	7,600	9,000	10,500	9,600	115
120	5,800	6,600	7,300	7,900	6,600	7,900	9,300	9,500	120
125	4,900	5,600	6,300	6,800	5,700	6,900	8,200	9,300	125
130	4,100	4,800	5,400	5,900	4,800	6,000	7,200	8,200	130
135	3,300	4,000	4,600	5,000	4,000	5,200	6,300	7,200	135
140	2,600	3,200	3,800	4,200	3,300	4,400	5,500	6,300	140
145		2,600	3,100	3,400	2,700	3,700	4,700	5,500	145
150			2,400	2,700	2,100	3,000	4,000	4,700	150
155				2,100		2,400	3,300	3,900	155
160							2,700	3,300	160
165							2,100	2,600	165
170									170
175									175
180									180

This information is not for crane operation. Operator must refer to the in-cab information for crane operation. Rated lifting capacities shown on fully extended outriggers do not exceed 85% of the tipping loads.

115,500 lb Counterweight - Fully Extended Outriggers - 360° Rotation (All Capacities Are Listed In Pounds)									
200.1 ft Main Boom Length									
Radius (ft)	40 ft Hydraulic Offset Fly				67 ft Hydraulic Offset Fly				Radius (ft)
	2°–4°	4.1°–15°	15°–30°	30°–45°	2°–4°	4.1°–15°	15°–30°	30°–45°	
40	16,100	16,100							40
45	16,100	16,000	16,000		10,800	10,800			45
50	16,100	16,000	16,000		10,800	10,800			50
55	16,100	16,000	15,800	15,800	10,800	10,800			55
60	16,100	16,000	15,800	15,600	10,800	10,800	10,800		60
65	16,100	16,000	15,800	15,600	10,800	10,800	10,800		65
70	16,100	16,000	15,800	15,600	10,800	10,800	10,800		70
75	16,100	16,000	15,800	15,600	10,800	10,800	10,700	10,700	75
80	16,100	16,000	15,800	15,600	10,800	10,800	10,700	10,700	80
85	16,100	16,000	15,800	15,600	10,800	10,800	10,700	10,700	85
90	16,100	16,000	15,800	15,600	10,800	10,800	10,700	10,400	90
95	16,100	16,000	15,800	15,600	10,800	10,800	10,700	10,300	95
100	16,100	16,000	15,800	15,600	10,800	10,800	10,700	10,100	100
105	16,100	16,000	15,800	15,600	10,800	10,800	10,700	9,900	105
110	16,100	16,000	15,800	15,600	10,800	10,800	10,700	9,800	110
115	16,100	16,000	15,800	15,600	10,800	10,800	10,700	9,600	115
120	16,100	16,000	15,800	15,600	10,800	10,800	10,700	9,500	120
125	16,000	16,000	15,800	15,600	10,800	10,800	10,500	9,400	125
130	15,300	15,300	15,200	15,200	10,800	10,800	10,300	9,200	130
135	14,500	14,500	14,500	14,500	10,800	10,800	10,100	9,100	135
140	13,800	13,800	13,800	13,900	10,800	10,800	9,900	9,000	140
145	13,200	13,200	13,200	13,200	10,800	10,800	9,700	8,900	145
150	12,600	12,600	12,600	12,600	10,800	10,800	9,600	8,800	150
155	12,000	12,000	12,000	12,100	10,800	10,800	9,400	8,700	155
160	11,400	11,400	11,500	11,500	10,600	10,500	9,300	8,600	160
165	10,900	10,900	11,000	11,000	10,100	10,100	9,100	8,500	165
170	10,400	10,400	10,500	10,500	9,700	9,700	9,000	8,400	170
175	9,700	9,700	10,000	10,000	9,200	9,200	8,900	8,400	175
180	9,000	9,000	9,300	9,600	8,800	8,800	8,700	8,300	180
185	8,300	8,400	8,600	8,900	8,400	8,400	8,500	8,300	185
190	7,700	7,700	8,000	8,200	8,000	8,000	8,100	8,200	190
195	7,100	7,100	7,400	7,600	7,600	7,600	7,700	7,800	195
200	6,500	6,600	6,800	6,900	7,100	7,200	7,400	7,500	200
205	6,000	6,000	6,200	6,300	6,600	6,600	7,000	7,100	205
210	5,500	5,500	5,700	5,700	6,100	6,100	6,500	6,800	210
215	5,000	5,100	5,200	5,200	5,600	5,600	6,000	6,300	215
220	4,600	4,600	4,700		5,100	5,100	5,500	5,800	220
225	4,200	4,200			4,700	4,700	5,000	5,300	225
230					4,300	4,300	4,600	4,700	230
235					3,900	3,900	4,100	4,200	235
240					3,500	3,500	3,700	3,600	240
245					3,100	3,200	3,300		245
250					2,800	2,800			250

This information is not for crane operation. Operator must refer to the in-cab information for crane operation. Rated lifting capacities shown on fully extended outriggers do not exceed 85% of the tipping loads.

115,500 lb Counterweight - Fully Extended Outriggers - 360° Rotation (All Capacities Are Listed In Pounds)									
200.1 ft Main Boom Length									
Radius (ft)	92 ft Hydraulic Offset Fly				117 ft Hydraulic Offset Fly				Radius (ft)
	2°-4°	4.1°-15°	15°-30°	30°-45°	2°-4°	4.1°-15°	15°-30°	30°-45°	
55	8,200	8,200							55
60	8,200	8,200			6,600	6,600			60
65	8,200	8,100	8,100		6,600	6,600			65
70	8,200	8,100	8,100		6,600	6,600	6,600		70
75	8,200	8,100	8,100		6,600	6,600	6,600		75
80	8,200	8,100	8,100		6,600	6,600	6,600		80
85	8,200	8,100	8,000	8,000	6,600	6,600	6,600		85
90	8,200	8,100	8,000	8,000	6,600	6,600	6,600		90
95	8,200	8,100	8,000	7,800	6,600	6,600	6,400	6,400	95
100	8,200	8,100	8,000	7,800	6,600	6,600	6,400	6,400	100
105	8,200	8,100	8,000	7,800	6,600	6,600	6,400	6,200	105
110	8,200	8,100	8,000	7,800	6,600	6,600	6,400	6,200	110
115	8,200	8,100	8,000	7,800	6,600	6,600	6,400	6,200	115
120	8,200	8,100	8,000	7,800	6,600	6,600	6,400	6,200	120
125	8,200	8,100	8,000	7,800	6,600	6,600	6,400	6,200	125
130	8,200	8,100	8,000	7,800	6,600	6,600	6,400	6,200	130
135	8,200	8,100	8,000	7,800	6,600	6,600	6,400	6,200	135
140	8,200	8,100	8,000	7,800	6,600	6,600	6,400	6,200	140
145	8,200	8,100	8,000	7,800	6,600	6,600	6,400	6,100	145
150	8,200	8,100	8,000	7,700	6,600	6,600	6,300	5,900	150
155	8,200	8,100	8,000	7,500	6,600	6,600	6,100	5,800	155
160	8,200	8,100	7,900	7,400	6,600	6,400	5,900	5,600	160
165	8,200	8,100	7,700	7,200	6,600	6,200	5,700	5,400	165
170	8,200	8,100	7,500	7,100	6,500	6,000	5,500	5,300	170
175	8,000	8,000	7,400	7,000	6,300	5,800	5,400	5,100	175
180	7,600	7,600	7,200	6,900	6,000	5,600	5,200	4,900	180
185	7,200	7,200	7,100	6,700	5,800	5,400	5,000	4,800	185
190	6,800	6,800	6,900	6,600	5,600	5,200	4,800	4,600	190
195	6,500	6,500	6,700	6,500	5,300	5,000	4,700	4,500	195
200	6,100	6,100	6,300	6,400	5,100	4,800	4,500	4,400	200
205	5,800	5,800	6,000	6,100	4,700	4,600	4,400	4,200	205
210	5,500	5,500	5,600	5,800	4,400	4,400	4,200	4,100	210
215	5,200	5,200	5,300	5,500	4,100	4,200	4,100	4,000	215
220	4,900	4,900	5,000	5,200	3,800	3,900	3,900	3,900	220
225	4,500	4,600	4,800	4,900	3,600	3,600	3,800	3,800	225
230	4,100	4,100	4,500	4,600	3,300	3,300	3,500	3,600	230
235	3,700	3,700	4,100	4,300	3,100	3,100	3,300	3,500	235
240	3,300	3,300	3,700	4,000	2,800	2,800	3,000	3,200	240
245	2,900	3,000	3,300	3,500	2,600	2,600	2,800	2,900	245
250	2,600	2,600	2,900	3,100	2,400	2,400	2,600	2,700	250
255	2,300	2,300	2,500	2,600			2,300	2,500	255
260			2,200	2,200				2,200	260

This information is not for crane operation. Operator must refer to the in-cab information for crane operation. Rated lifting capacities shown on fully extended outriggers do not exceed 85% of the tipping loads.

Main Boom Lift Capacity Charts – Metric

16.3t Counterweight - Fully Extended Outriggers - 360° Rotation (All Capacities Are Listed In Kilograms)												
Radius (m)	Boom Length (m)											Radius (m)
	13.49	17.95–18.24	22.41–23.14	27.02–28.18	31.63–32.79	36.38–37.83	41.13–41.71	46.31–46.75	50.92–51.5	55.96–56.54	61	
3	130 200	130 800	118 900	96 200								3
3.5	118 900	119 700	118 700	96 200								3.5
4	109 250	110 250	109 500	96 050								4
4.5	100 900	102 050	101 400	92 350	58 500							4.5
5	91 300	93 100	92 350	91 400	78 750	29 950						5
6	75 500	77 350	77 800	77 500	76 600	59 350	41 450					6
7	63 850	65 750	66 300	66 100	65 300	54 750	41 450					7
8	53 900	57 050	57 050	56 750	55 750	54 750	41 400	33 100	18 700			8
9	41 700	44 750	45 900	46 100	45 650	44 700	39 050	33 100	24 900	18 750		9
10	33 450	36 500	37 550	37 700	37 300	36 450	37 100	33 100	24 900	18 750	14 950	10
12		26 000	27 400	27 150	27 900	27 500	26 700	27 050	24 900	18 750	14 950	12
14		19 550	21 000	21 500	21 500	21 750	21 400	20 700	20 150	18 750	14 950	14
16			16 650	17 150	17 450	17 400	17 350	16 400	16 750	16 250	14 950	16
18			13 500	14 100	14 400	14 350	14 300	13 400	13 750	13 250	12 850	18
20			10 050	11 700	12 050	12 000	11 950	11 100	11 450	10 950	10 550	20
22				9 850	10 250	10 200	10 150	9 300	9 600	9 150	8 750	22
24				8 400	8 750	8 750	8 700	7 850	8 150	7 700	7 400	24
26					7 550	7 600	7 550	6 700	7 050	6 550	6 150	26
28					6 450	6 500	6 500	5 650	6 000	5 500	5 100	28
30					2 900	5 550	5 600	4 750	5 100	4 600	4 200	30
32						4 800	4 800	3 950	4 350	3 850	3 450	32
34						3 650	4 100	3 250	3 650	3 200	2 800	34
36							3 500	2 650	3 050	2 600	2 200	36
38							3 000	2 150	2 500	2 100	1 700	38
40								1 700	2 050	1 600	1 250	40
42								1 250	1 650	1 200		42
44									1 250			44
46									950			46

Note: Capacities depict multiple boom modes.

This information is not for crane operation. Operator must refer to the in-cab information for crane operation. Rated lifting capacities shown on fully extended outriggers do not exceed 75% of the tipping loads.

Main Boom Lift Capacity Charts – Optional – Metric

52.4t Counterweight - Fully Extended Outriggers - 360° Rotation (All Capacities Are Listed In Kilograms)												
Radius (m)	Boom Length (m)											Radius (m)
	13.49	17.95—18.24	22.41—23.14	27.02—28.18	31.63—32.79	36.38—37.82	41.13—41.71	46.31—46.75	50.92—51.5	55.96—56.54	61	
2.5	185 000 **											2.5
3	136 000											3
	150 000*	135 950	118 900	96 200								
3.5	124 850											3.5
	140 050*	125 350	118 700	96 200								
4	115 250											4
	131 750*	116 000	112 050	96 050								
4.5	106 900											4.5
	124 250*	107 800	106 100	92 350	58 500							
5	99 550											5
	114 450*	100 600	99 900	92 350	78 750	29 950						
6	87 000											6
	95 050*	88 200	87 650	84 450	78 750	59 350	41 450					
7	76 850											7
	80 850*	78 250	77 800	77 200	72 700	54 750	41 450					
8	68 650											8
	70 000*	70 100	69 700	69 150	67 500	54 750	41 400	33 100	18 700			
9	61 400	63 300	62 900	62 300	62 900	54 200	39 050	33 100	24 900	18 750		9
10	54 450	56 350	56 950	55 850	56 150	50 850	37 100	33 100	24 900	18 750	14 950	10
12		45 900	46 500	46 400	45 800	45 350	33 650	32 000	24 900	18 750	14 950	12
14		38 700	38 900	38 850	38 300	39 050	30 750	28 450	24 900	18 750	14 950	14
16			33 550	33 350	33 550	32 850	28 200	25 500	23 550	18 750	14 950	16
18			28 150	28 400	28 100	27 400	26 150	23 050	21 900	18 450	14 950	18
20			23 250	24 150	23 900	23 350	23 800	20 900	19 900	17 000	14 950	20
22				20 950	20 750	21 100	20 650	19 100	18 250	15 750	14 950	22
24				18 300	18 100	18 650	18 050	17 500	16 750	14 650	14 150	24
26					16 650	16 500	15 900	15 800	15 450	13 650	13 200	26
28					15 050	14 750	14 250	14 500	14 050	12 750	12 300	28
30					11 450	13 250	12 700	12 950	12 550	11 950	11 500	30
32						11 950	11 950	11 700	11 250	10 850	10 800	32
34						9 750	11 050	10 550	10 150	9 750	10 000	34
36							10 050	9 550	9 150	8 750	9 100	36
38							9 200	8 700	8 250	8 200	8 250	38
40								7 900	7 500	7 700	7 500	40
42								7 200	6 750	7 150	6 750	42
44								4 800	6 100	6 450	6 100	44
46									5 700	5 850	5 500	46
48									5 400	5 300	4 950	48
50										4 800	4 450	50
52										4 350	4 000	52
54											3 550	54
56											3 200	56
58												58

Note: Capacities depict multiple boom modes.
 * Boom centered over rear, intermediate outriggers
 ** Over rear intermediate outriggers, additional equipment required.

This information is not for crane operation. Operator must refer to the in-cab information for crane operation. Rated lifting capacities shown on fully extended outriggers do not exceed 75% of the tipping loads.

Manual & Hydraulic Offset Fly Attachment Lift Capacity Charts – Optional – Metric

16.3t Counterweight - Fully Extended Outriggers - 360° Rotation (All Capacities Are Listed In Kilograms)

Main Boom + 3.7m Offset Fly (Manual Offsets 2°, 15°, 30°, 45° & Hydraulic Offsets 2°-4°, 4.1°- 45°)

Radius (m)	Boom Length (m)												Radius (m)
	13.49		17.9–18.2		22.4–23.1		27.0–28.1		31.6–32.7		36.3–37.8		
	2°–4°	4.1°–45°	2°–4°	4.1°–45°	2°–4°	4.1°–45°	2°–4°	4.1°–45°	2°–4°	4.1°–45°	2°–4°	4.1°–45°	
3.0	31 600	31 600	31 550	31 550	31 500	31 500	31 450	31 450					3.0
3.5	31 600	31 600	31 550	31 550	31 500	31 500	31 450	31 450					3.5
4.0	31 600	31 600	31 550	31 550	31 500	31 500	31 450	31 450					4.0
4.5	31 600	31 600	31 550	31 550	31 500	31 500	31 450	31 450	31 400	31 400	31 350	31 350	4.5
5.0	31 600	31 600	31 550	31 550	31 500	31 500	31 450	31 450	31 400	31 400	31 350	31 350	5.0
6.0	31 600	31 600	31 550	31 550	31 500	31 500	31 450	31 450	31 400	31 400	31 350	31 350	6.0
7.0	31 600	31 600	31 550	31 550	31 500	31 500	31 450	31 450	31 400	31 400	31 350	31 350	7.0
8.0	31 600	31 600	31 550	31 550	31 500	31 500	31 450	31 450	31 400	31 400	31 350	31 350	8.0
9.0	31 600	31 600	31 550	31 550	31 500	31 500	31 450	31 450	31 400	31 400	31 350	31 350	9.0
10.0	31 600	30 900	31 550	31 550	31 500	31 500	31 450	31 450	31 400	31 400	31 350	31 350	10.0
12.0	25 350	25 350	26 650	26 650	27 150	27 150	27 100	27 100	27 200	26 600	27 150	27 150	12.0
14.0	19 150	19 150	20 350	20 350	21 150	20 800	21 400	21 150	21 250	21 250	20 800	20 800	14.0
16.0			16 100	16 100	16 800	16 800	17 050	17 050	16 900	16 900	17 050	17 050	16.0
18.0			13 100	13 100	13 750	13 750	14 000	14 000	14 150	14 150	14 000	14 000	18.0
20.0					11 450	11 450	11 650	11 650	11 800	11 800	11 650	11 650	20.0
22.0					9 650	9 650	9 850	9 850	10 000	10 000	9 850	9 850	22.0
24.0							8 400	8 400	8 500	8 500	8 400	8 400	24.0
26.0							7 250	7 250	7 400	7 400	7 250	7 250	26.0
28.0							4 600	4 600	6 350	6 350	6 200	6 200	28.0
30.0									5 450	5 450	5 300	5 300	30.0
32.0									4 700	4 700	4 550	4 550	32.0
34.0											3 850	3 850	34.0
36.0											3 300	3 300	36.0
38.0													38.0
40.0													40.0
42.0													42.0

Note: Capacities depict multiple boom modes.

This information is not for crane operation. Operator must refer to the in-cab information for crane operation. Rated lifting capacities shown on fully extended outriggers do not exceed 85% of the tipping loads.

16.3t Counterweight - Fully Extended Outriggers - 360° Rotation (All Capacities Are Listed In Kilograms)											
Main Boom + 3.7m Offset Fly (Manual Offsets 2°, 15°, 30°, 45° & Hydraulic Offsets 2°-4°, 4.1°- 45°)											
Radius (m)	Boom Length (m)										Radius (m)
	41.1–41.7		46.3–46.7		50.9–51.5		55.9–56.5		61		
	2°–4°	4.1°–45°	2°–4°	4.1°–45°	2°–4°	4.1°–45°	2°–4°	4.1°–45°	2°–4°	4.1°–45°	
3.0											3.0
3.5											3.5
4.0											4.0
4.5											4.5
5.0	19 600	19 500									5.0
6.0	25 600	25 150									6.0
7.0	31 350	31 350	27 300	26 700	16 200	16 150					7.0
8.0	31 350	31 350	27 300	26 700	19 900	19 500					8.0
9.0	31 350	31 350	27 300	26 700	19 900	19 500	16 300	16 050			9.0
10.0	31 350	31 350	27 300	26 700	19 900	19 500	16 300	16 050	12 950	12 750	10.0
12.0	26 300	26 300	25 600	25 600	19 900	19 500	16 300	16 050	12 950	12 750	12.0
14.0	20 950	20 950	20 250	20 250	19 650	19 500	16 300	16 050	12 950	12 750	14.0
16.0	16 650	16 650	15 950	15 950	16 200	15 950	15 150	15 000	12 950	12 750	16.0
18.0	13 900	13 900	13 000	13 000	13 250	13 250	12 750	12 750	12 300	12 300	18.0
20.0	11 550	11 550	10 650	10 650	10 950	10 950	10 450	10 450	10 000	10 000	20.0
22.0	9 750	9 750	8 850	8 850	9 150	9 150	8 650	8 650	8 150	8 150	22.0
24.0	8 250	8 250	7 450	7 450	7 750	7 750	7 250	7 250	6 800	6 800	24.0
26.0	7 150	7 150	6 200	6 200	6 500	6 500	6 000	6 000	5 550	5 550	26.0
28.0	6 100	6 100	5 150	5 150	5 450	5 450	4 950	4 950	4 500	4 500	28.0
30.0	5 200	5 200	4 250	4 250	4 550	4 550	4 050	4 050	3 600	3 600	30.0
32.0	4 400	4 400	3 500	3 500	3 800	3 800	3 300	3 300	2 850	2 850	32.0
34.0	3 750	3 750	2 850	2 850	3 150	3 150	2 600	2 600	2 200	2 200	34.0
36.0	3 150	3 150	2 250	2 250	2 550	2 550	2 050	2 050	1 650	1 650	36.0
38.0	2 650	2 650	1 750	1 750	2 050	2 050	1 550	1 550	1 100	1 100	38.0
40.0	2 200	2 200	1 300	1 300	1 600	1 600	1 100	1 100			40.0
42.0					1 200	1 200					42.0

Note: Capacities depict multiple boom modes.

This information is not for crane operation. Operator must refer to the in-cab information for crane operation. Rated lifting capacities shown on fully extended outriggers do not exceed 85% of the tipping loads.

54.2t Counterweight - Fully Extended Outriggers - 360° Rotation (All Capacities Are Listed In Pounds)													
Main Boom + 3.7m Offset Fly (Manual Offsets 2°, 15°, 30°, 45° & Hydraulic Offsets 2°-4°, 4.1°- 45°)													
Radius (m)	Boom Length (m)												Radius (m)
	13.4		17.9–18.2		22.4–23.1		27.0–28.1		31.6–32.7		36.3–37.8		
	2°–4°	4.1°–45°	2°–4°	4.1°–45°	2°–4°	4.1°–45°	2°–4°	4.1°–45°	2°–4°	4.1°–45°	2°–4°	4.1°–45°	
3.0	31 600	31 600	31 550	31 550	31 500	31 500	31 450	31 450					3.0
3.5	31 600	31 600	31 550	31 550	31 500	31 500	31 450	31 450					3.5
4.0	31 600	31 600	31 550	31 550	31 500	31 500	31 450	31 450					4.0
4.5	31 600	31 600	31 550	31 550	31 500	31 500	31 450	31 450	31 400	31 400	31 350	31 350	4.5
5.0	31 600	31 600	31 550	31 550	31 500	31 500	31 450	31 450	31 400	31 400	31 350	31 350	5.0
6.0	31 600	31 600	31 550	31 550	31 500	31 500	31 450	31 450	31 400	31 400	31 350	31 350	6.0
7.0	31 600	31 600	31 550	31 550	31 500	31 500	31 450	31 450	31 400	31 400	31 350	31 350	7.0
8.0	31 600	31 600	31 550	31 550	31 500	31 500	31 450	31 450	31 400	31 400	31 350	31 350	8.0
9.0	31 600	31 600	31 550	31 550	31 500	31 500	31 450	31 450	31 400	31 400	31 350	31 350	9.0
10.0	31 600	30 900	31 550	31 550	31 500	31 500	31 450	31 450	31 400	31 400	31 350	31 350	10.0
12.0	31 600	27 650	31 550	31 550	31 500	31 500	31 450	31 450	31 400	31 400	31 350	31 350	12.0
14.0	27 850	25 750	31 550	29 650	31 500	31 500	31 450	31 450	31 400	31 400	31 350	31 350	14.0
16.0			31 550	27 550	31 500	31 350	31 450	31 450	31 400	31 400	31 350	31 350	16.0
18.0			27 700	26 050	27 700	27 700	28 100	27 650	27 900	27 900	27 150	27 150	18.0
20.0					24 250	24 250	24 150	24 150	23 700	23 700	23 100	23 100	20.0
22.0					21 050	21 050	20 950	20 950	20 550	20 550	19 850	19 850	22.0
24.0							18 350	18 350	17 950	17 950	17 300	17 300	24.0
26.0							16 250	16 250	15 850	15 850	16 100	15 650	26.0
28.0							13 650	13 650	14 100	14 100	14 500	14 500	28.0
30.0									12 650	12 650	13 000	13 000	30.0
32.0									11 950	11 800	11 700	11 700	32.0
34.0											10 600	10 600	34.0
36.0											9 650	9 650	36.0
38.0											6 700	6 700	38.0
40.0													40.0
42.0													42.0
44.0													44.0
46.0													46.0
48.0													48.0
50.0													50.0
52.0													52.0
54.0													54.0

Note: Capacities depict multiple boom modes.

This information is not for crane operation. Operator must refer to the in-cab information for crane operation. Rated lifting capacities shown on fully extended outriggers do not exceed 85% of the tipping loads.

54.2t Counterweight - Fully Extended Outriggers - 360° Rotation (All Capacities Are Listed In Pounds)											
Main Boom + 3.7m Offset Fly (Manual Offsets 2°, 15°, 30°, 45° & Hydraulic Offsets 2°-4°, 4.1°- 45°)											
Radius (m)	Boom Length (m)										Radius (m)
	41.1–41.7		46.3–46.7		50.9–51.5		55.9–56.5		61		
	2°–4°	4.1°–45°	2°–4°	4.1°–45°	2°–4°	4.1°–45°	2°–4°	4.1°–45°	2°–4°	4.1°–45°	
3.0											3.0
3.5											3.5
4.0											4.0
4.5											4.5
5.0	19 600	19 500									5.0
6.0	25 600	25 150									6.0
7.0	31 350	31 350	27 300	26 700	16 200	16 150					7.0
8.0	31 350	31 350	27 300	26 700	19 900	19 500					8.0
9.0	31 350	31 350	27 300	26 700	19 900	19 500	16 300	16 050			9.0
10.0	31 350	31 350	27 300	26 700	19 900	19 500	16 300	16 050	12 950	12 750	10.0
12.0	31 050	29 200	27 300	26 700	19 900	19 500	16 300	16 050	12 950	12 750	12.0
14.0	28 100	26 550	27 300	26 700	19 900	19 500	16 300	16 050	12 950	12 750	14.0
16.0	25 600	24 350	24 650	24 600	19 900	19 500	16 300	16 050	12 950	12 750	16.0
18.0	23 500	22 400	22 150	22 150	19 900	19 300	16 300	16 050	12 950	12 750	18.0
20.0	21 700	20 750	20 150	20 150	18 600	17 950	16 050	15 850	12 950	12 750	20.0
22.0	20 100	19 350	18 300	18 300	17 350	16 750	14 750	14 600	12 950	12 750	22.0
24.0	17 700	17 700	16 700	16 700	16 000	15 700	13 650	13 500	12 950	12 750	24.0
26.0	15 650	15 650	15 150	15 150	14 650	14 650	12 650	12 550	12 200	12 100	26.0
28.0	13 900	13 900	13 400	13 400	13 500	13 500	11 750	11 650	11 300	11 250	28.0
30.0	12 400	12 400	12 550	12 350	12 100	12 100	10 900	10 850	10 500	10 450	30.0
32.0	11 100	11 100	11 250	11 250	10 800	10 800	10 050	10 000	9 750	9 700	32.0
34.0	10 000	10 000	10 150	10 150	9 700	9 700	9 250	9 250	9 150	9 100	34.0
36.0	9 350	9 250	9 200	9 200	8 700	8 700	8 250	8 250	8 550	8 500	36.0
38.0	8 800	8 700	8 300	8 300	7 800	7 800	7 450	7 450	7 700	7 700	38.0
40.0	8 150	8 150	7 600	7 600	7 050	7 050	6 850	6 850	6 950	6 950	40.0
42.0	6 700	6 700	6 850	6 850	6 350	6 350	6 400	6 400	6 200	6 200	42.0
44.0			6 200	6 200	5 700	5 700	6 000	6 000	5 550	5 550	44.0
46.0			5 650	5 650	5 100	5 100	5 400	5 400	4 950	4 950	46.0
48.0					4 550	4 550	4 850	4 850	4 450	4 450	48.0
50.0					4 050	4 050	4 350	4 350	3 950	3 950	50.0
52.0					2 850	2 850	3 900	3 900	3 500	3 500	52.0
54.0							3 500	3 500	3 100	3 100	54.0
56.0									2 700	2 700	56.0
58.0									2 350	2 350	58.0

Note: Capacities depict multiple boom modes.

This information is not for crane operation. Operator must refer to the in-cab information for crane operation. Rated lifting capacities shown on fully extended outriggers do not exceed 85% of the tipping loads.

Manual Offset Fly Attachment Lift Capacity Charts – Optional – Metric

16.3t Counterweight - Fully Extended Outriggers - 360° Rotation
(All Capacities Are Listed In Kilograms)

61m Main Boom Length

Radius (m)	12.2m Manual Offset Fly				20.4m Manual Offset Fly				Radius (m)
	2°–4°	4.1°–15°	15°–30°	30°–45°	2°–4°	4.1°–15°	15°–30°	30°–45°	
12	7 300								12
14	7 300								14
16	7 300	7 300			4 900				16
18	7 300	7 300			4 900				18
20	7 300	7 300	7 200		4 900	4 900			20
22	7 300	7 300	7 200	7 100	4 900	4 900			22
24	7 300	7 300	7 200	7 100	4 900	4 900			24
26	6 050	6 600	7 200	7 100	4 900	4 900	4 900		26
28	4 950	5 450	6 000	6 400	4 900	4 900	4 900		28
30	4 050	4 500	5 000	5 350	4 450	4 900	4 900	4 600	30
32	3 300	3 700	4 150	4 450	3 650	4 400	4 900	4 500	32
34	2 600	3 000	3 400	3 700	2 950	3 650	4 400	4 400	34
36	2 050	2 400	2 750	3 000	2 400	3 000	3 650	4 200	36
38	1 500	1 850	2 150	2 400	1 850	2 450	3 050	3 500	38
40	1 050	1 350	1 650	1 850	1 400	1 900	2 500	2 900	40
42			1 200	1 350	950	1 450	2 000	2 350	42
44				950		1 050	1 550	1 900	44
46							1 100	1 450	46
48								1 050	48

This information is not for crane operation. Operator must refer to the in-cab information for crane operation. Rated lifting capacities shown on fully extended outriggers do not exceed 75% of the tipping loads.

52.4t Counterweight - Fully Extended Outriggers - 360° Rotation (All Capacities Are Listed In Kilograms)									
61m Main Boom Length									
Radius (m)	12.2m Manual Offset Fly				20.4m Manual Offset Fly				Radius (m)
	2°	15°	30°	45°	2°	15°	30°	45°	
12	7 300								12
14	7 300								14
16	7 300	7 300			4 900				16
18	7 300	7 300			4 900				18
20	7 300	7 300	7 200		4 900	4 900			20
22	7 300	7 300	7 200	7 100	4 900	4 900			22
24	7 300	7 300	7 200	7 100	4 900	4 900			24
26	7 300	7 300	7 200	7 100	4 900	4 900	4 900		26
28	7 300	7 300	7 200	7 100	4 900	4 900	4 900		28
30	7 300	7 300	7 200	7 100	4 900	4 900	4 900	4 600	30
32	7 300	7 300	7 200	7 100	4 900	4 900	4 900	4 500	32
34	7 300	7 300	7 200	7 100	4 900	4 900	4 900	4 400	34
36	7 300	7 300	7 200	7 100	4 900	4 900	4 900	4 300	36
38	7 300	7 300	7 200	7 100	4 900	4 900	4 750	4 250	38
40	6 850	6 850	6 800	6 800	4 900	4 900	4 650	4 150	40
42	6 400	6 400	6 400	6 400	4 900	4 900	4 550	4 100	42
44	5 900	6 000	6 050	6 050	4 900	4 900	4 450	4 050	44
46	5 300	5 550	5 700	5 700	4 900	4 900	4 350	3 950	46
48	4 750	5 000	5 200	5 300	4 900	4 850	4 250	3 900	48
50	4 300	4 500	4 650	4 750	4 550	4 700	4 150	3 850	50
52	3 800	4 000	4 150	4 250	4 100	4 400	4 050	3 800	52
54	3 400	3 550	3 700	3 750	3 700	4 000	4 000	3 800	54
56	3 000	3 150	3 300	3 350	3 300	3 600	3 850	3 750	56
58	2 650	2 800	2 900	2 950	2 950	3 200	3 450	3 600	58
60	2 350	2 450	2 550		2 600	2 850	3 050	3 200	60
62	2 050	2 150	2 200		2 300	2 500	2 700	2 800	62
64	1 750	1 850	1 900		2 000	2 200	2 400	2 450	64
66	1 500	1 550	1 600		1 750	1 900	2 050	2 100	66
68	1 250	1 300			1 450	1 650	1 750		68
70					1 250	1 400	1 500		70
72					1 000	1 150	1 200		72
74							950		74

This information is not for crane operation. Operator must refer to the in-cab information for crane operation. Rated lifting capacities shown on fully extended outriggers do not exceed 75% of the tipping loads.

**52.4t Counterweight - Fully Extended Outriggers - 360° Rotation
(All Capacities Are Listed In Kilograms)**

61m Main Boom Length

Radius (m)	28m Manual Offset Fly				35.6m Manual Offset Fly				Radius (m)
	2°	15°	30°	45°	2°	15°	30°	45°	
18	3 700								18
20	3 700				3 050				20
22	3 700	3 700			3 050				22
24	3 700	3 700			3 050	3 000			24
26	3 700	3 700			3 050	3 000			26
28	3 700	3 700	3 650		3 050	3 000			28
30	3 700	3 700	3 650	3 550	3 050	3 000	2 950		30
32	3 700	3 700	3 650	3 550	3 050	3 000	2 950		32
34	3 700	3 700	3 650	3 550	3 050	3 000	2 950	2 850	34
36	3 700	3 700	3 650	3 550	3 050	3 000	2 950	2 850	36
38	3 700	3 700	3 650	3 550	3 050	3 000	2 950	2 850	38
40	3 700	3 700	3 650	3 550	3 050	3 000	2 950	2 850	40
42	3 700	3 700	3 650	3 550	3 050	3 000	2 950	2 850	42
44	3 700	3 700	3 650	3 550	3 050	3 000	2 950	2 800	44
46	3 700	3 700	3 650	3 450	3 050	3 000	2 850	2 700	46
48	3 700	3 700	3 600	3 400	3 050	2 950	2 700	2 600	48
50	3 700	3 700	3 500	3 300	3 050	2 850	2 600	2 500	50
52	3 700	3 700	3 400	3 200	2 950	2 700	2 500	2 400	52
54	3 550	3 650	3 300	3 150	2 800	2 600	2 400	2 300	54
56	3 250	3 400	3 200	3 050	2 650	2 450	2 300	2 200	56
58	2 850	3 150	3 150	3 000	2 550	2 350	2 200	2 100	58
60	2 550	2 850	3 050	2 900	2 400	2 200	2 100	2 000	60
62	2 200	2 500	2 750	2 850	2 100	2 100	2 000	1 950	62
64	1 950	2 200	2 400	2 550	1 850	2 000	1 900	1 850	64
66	1 650	1 900	2 100	2 200	1 550	1 800	1 850	1 800	66
68	1 400	1 600	1 800	1 900	1 300	1 550	1 750	1 700	68
70	1 150	1 350	1 500	1 600	1 050	1 300	1 500	1 600	70
72	950	1 100	1 250	1 300		1 050	1 250	1 300	72
74			1 000	1 000			1 000	1 050	74

This information is not for crane operation. Operator must refer to the in-cab information for crane operation. Rated lifting capacities shown on fully extended outriggers do not exceed 75% of the tipping loads.

Hydraulic Offset Fly Attachment Lift Capacity Charts – Optional – Metric

16.3t Counterweight - Fully Extended Outriggers - 360° Rotation
(All Capacities Are Listed In Kilograms)

61m Main Boom Length

Radius (m)	12.2m Hydraulic Offset Fly				20.4m Hydraulic Offset Fly				Radius (m)
	2°–4°	4.1°–15°	15°–30°	30°–45°	2°–4°	4.1°–15°	15°–30°	30°–45°	
12.0	7,300								12.0
14.0	7,300				4,900				14.0
16.0	7,300	7,300			4,900				16.0
18.0	7,300	7,300			4,900				18.0
20.0	7,300	7,300	7,200		4,900	4,900			20.0
22.0	7,300	7,300	7,200	7,100	4,900	4,900			22.0
24.0	7,300	7,300	7,200	7,100	4,900	4,900			24.0
26.0	6,050	6,600	7,200	7,100	4,900	4,900	4,900		26.0
28.0	4,950	5,450	6,000	6,400	4,900	4,900	4,900		28.0
30.0	4,050	4,500	5,000	5,350	4,450	4,900	4,900	4,600	30.0
32.0	3,300	3,700	4,150	4,450	3,650	4,400	4,900	4,500	32.0
34.0	2,600	3,000	3,400	3,700	2,950	3,650	4,400	4,400	34.0
36.0	2,050	2,400	2,750	3,000	2,400	3,000	3,650	4,200	36.0
38.0	1,500	1,850	2,150	2,400	1,850	2,450	3,050	3,500	38.0
40.0	1,050	1,350	1,650	1,850	1,400	1,900	2,500	2,900	40.0
42.0			1,200	1,350	950	1,450	2,000	2,350	42.0
44.0				950		1,050	1,550	1,900	44.0
46.0							1,100	1,450	46.0
48.0								1,050	48.0

This information is not for crane operation. Operator must refer to the in-cab information for crane operation. Rated lifting capacities shown on fully extended outriggers do not exceed 75% of the tipping loads.

**52.4t Counterweight - Fully Extended Outriggers - 360° Rotation
(All Capacities Are Listed In Kilograms)**

61m Main Boom Length

Radius (m)	12.2m Hydraulic Offset Fly				20.4m Hydraulic Offset Fly				Radius (m)
	2°–4°	4.1°–15°	15°–30°	30°–45°	2°–4°	4.1°–15°	15°–30°	30°–45°	
12.0	7 300	7 300							12.0
14.0	7 300	7 250	7 250		4 900	4 900			14.0
16.0	7 300	7 250	7 250		4 900	4 900			16.0
18.0	7 300	7 250	7 200	7 200	4 900	4 900	4 900		18.0
20.0	7 300	7 250	7 200	7 100	4 900	4 900	4 900		20.0
22.0	7 300	7 250	7 200	7 100	4 900	4 900	4 900		22.0
24.0	7 300	7 250	7 200	7 100	4 900	4 900	4 850	4 850	24.0
26.0	7 300	7 250	7 200	7 100	4 900	4 900	4 850	4 850	26.0
28.0	7 300	7 250	7 200	7 100	4 900	4 900	4 850	4 700	28.0
30.0	7 300	7 250	7 200	7 100	4 900	4 900	4 850	4 600	30.0
32.0	7 300	7 250	7 200	7 100	4 900	4 900	4 850	4 500	32.0
34.0	7 300	7 250	7 200	7 100	4 900	4 900	4 850	4 400	34.0
36.0	7 300	7 250	7 200	7 100	4 900	4 900	4 850	4 300	36.0
38.0	7 300	7 250	7 200	7 100	4 900	4 900	4 750	4 250	38.0
40.0	6 850	6 850	6 800	6 800	4 900	4 900	4 650	4 150	40.0
42.0	6 400	6 400	6 400	6 400	4 900	4 900	4 550	4 100	42.0
44.0	5 900	5 950	6 000	6 050	4 900	4 900	4 450	4 050	44.0
46.0	5 300	5 350	5 550	5 700	4 900	4 900	4 350	3 950	46.0
48.0	4 750	4 800	5 000	5 200	4 900	4 850	4 250	3 900	48.0
50.0	4 300	4 300	4 500	4 650	4 550	4 600	4 150	3 850	50.0
52.0	3 800	3 850	4 000	4 150	4 100	4 150	4 050	3 800	52.0
54.0	3 400	3 400	3 550	3 700	3 700	3 700	4 000	3 800	54.0
56.0	3 000	3 050	3 150	3 300	3 300	3 300	3 600	3 750	56.0
58.0	2 650	2 650	2 800	2 900	2 950	2 950	3 200	3 450	58.0
60.0	2 350	2 350	2 450	2 550	2 600	2 600	2 850	3 050	60.0
62.0	2 050	2 050	2 150	2 200	2 300	2 300	2 500	2 700	62.0
64.0	1 750	1 750	1 850	1 850	2 000	2 000	2 200	2 400	64.0
66.0	1 500	1 500	1 550	1 500	1 750	1 750	1 900	2 050	66.0
68.0	1 250	1 250			1 450	1 500	1 650	1 750	68.0
70.0					1 250	1 250	1 400	1 450	70.0
72.0					1 000	1 050	1 150	1 150	72.0
74.0					3 100	3 200	3 300		74.0
76.0					2 800	2 800			76.0

This information is not for crane operation. Operator must refer to the in-cab information for crane operation. Rated lifting capacities shown on fully extended outriggers do not exceed 75% of the tipping loads.

52.4t Counterweight - Fully Extended Outriggers - 360° Rotation (All Capacities Are Listed In Kilograms)									
61m Main Boom Length									
Radius (m)	28m Hydraulic Offset Fly				35.7m Hydraulic Offset Fly				Radius (m)
	2°-4°	4.1°-15°	15°-30°	30°-45°	2°-4°	4.1°-15°	15°-30°	30° - 45°	
18.0	3 700	3 700							18.0
20.0	3 700	3 650	3 650		3 000	3 000			20.0
22.0	3 700	3 650	3 650		3 000	3 000	3 000		22.0
24.0	3 700	3 650	3 650		3 000	3 000	3 000		24.0
26.0	3 700	3 650	3 600	3 600	3 000	3 000	3 000		26.0
28.0	3 700	3 650	3 600	3 600	3 000	3 000	2 900	2 900	28.0
30.0	3 700	3 650	3 600	3 550	3 000	3 000	2 900	2 900	30.0
32.0	3 700	3 650	3 600	3 550	3 000	3 000	2 900	2 850	32.0
34.0	3 700	3 650	3 600	3 550	3 000	3 000	2 900	2 850	34.0
36.0	3 700	3 650	3 600	3 550	3 000	3 000	2 900	2 850	36.0
38.0	3 700	3 650	3 600	3 550	3 000	3 000	2 900	2 850	38.0
40.0	3 700	3 650	3 600	3 550	3 000	3 000	2 900	2 850	40.0
42.0	3 700	3 650	3 600	3 550	3 000	3 000	2 900	2 850	42.0
44.0	3 700	3 650	3 600	3 550	3 000	3 000	2 900	2 800	44.0
46.0	3 700	3 650	3 600	3 450	3 000	3 000	2 850	2 700	46.0
48.0	3 700	3 650	3 600	3 400	3 000	2 950	2 700	2 600	48.0
50.0	3 700	3 650	3 500	3 300	3 000	2 850	2 600	2 500	50.0
52.0	3 700	3 650	3 400	3 200	2 950	2 700	2 500	2 400	52.0
54.0	3 550	3 550	3 300	3 150	2 800	2 600	2 400	2 300	54.0
56.0	3 250	3 250	3 200	3 050	2 650	2 450	2 300	2 200	56.0
58.0	2 850	2 900	3 150	3 000	2 500	2 350	2 200	2 100	58.0
60.0	2 550	2 550	2 850	2 900	2 400	2 200	2 100	2 000	60.0
62.0	2 200	2 250	2 500	2 750	2 100	2 100	2 000	1 950	62.0
64.0	1 950	1 950	2 200	2 400	1 850	1 850	1 900	1 850	64.0
66.0	1 650	1 700	1 900	2 100	1 550	1 600	1 800	1 800	66.0
68.0	1 400	1 400	1 600	1 800	1 300	1 300	1 550	1 700	68.0
70.0	1 150	1 200	1 350	1 500	1 050	1 050	1 300	1 500	70.0
72.0	0 950	0 950	1 100	1 250			1 050	1 250	72.0
74.0				1 000				1 000	74.0

This information is not for crane operation. Operator must refer to the in-cab information for crane operation. Rated lifting capacities shown on fully extended outriggers do not exceed 75% of the tipping loads.

Link-Belt Cranes Lexington, Kentucky www.linkbelt.com

®Link-Belt is a registered trademark. Copyright 2019 We are constantly improving our products and therefore reserve the right to change designs and specifications.